



End Mill Holders

ER/TG/DA Collet Chucks

Shell Mill Holders

Drill Chucks



Current Promotion

Scan
these
QR Codes



Featured Video

Drill Chuck Features

High-Precision, high-rigidity, compact design and safe

Our Drill Chucks feature a unique compact design and small head which prevent the drill from slipping during drilling operations.

- Balanced to 12,000RPM
- High Precision .0005 or better runout at 4xD
- Coolant-thru capable
- Short compact two-pieces design for flexible replacement of head only
- Maintenance free

Taper ground to AT3 or better to ensure 80% taper contact

Nickel Chrome 4140 Alloy body

Nickel Chrome 4140 alloy body

Hardened Lead Screw and ground pilot contribute to provide an additional 28% clamping force compared to other drill chucks

Nickel Chrome Molybdenum Ground 4340 alloy jaws hardened to 60Rc

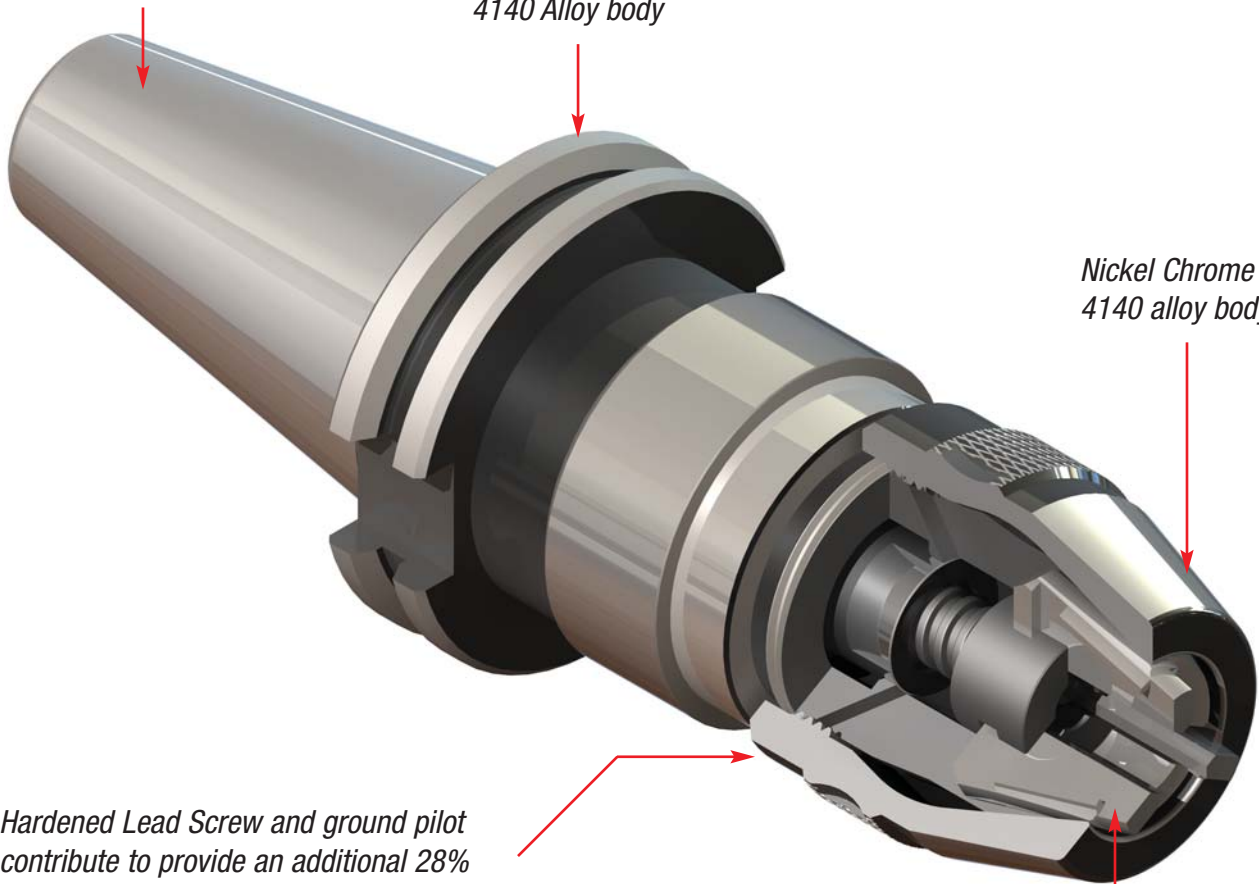

CAT and BT Integral Keyless Drill Chucks

- Compact design and small head prevent drill slippage during operation
- Balanced to 12,000RPM
- High precision .0005" or better runout at 4xD
- Coolant-thru capable

Please note that the maximum RPM listed in our catalog may vary depending on the toolholder shank, weight, balanceability and the G rating.



TIR: minimal



Speed: up to 12,000 rpm



Set-up: quick and easy



Coolant-thru: available



Drilling

★★★★☆



Reaming

★★★★☆

CAT40/50 Taper

Part Number	Taper	Capacity	L	L1	D
CAT40-NPU8-80U	CT40	0-5/16" (0-8mm)	3.40"	3.68"	1.36"
CAT40-NPU8-110U	CT40	0-5/16" (0-8mm)	4.54"	4.82"	1.36"
CAT40-NPU13-105U	CT40	3/32-1/2" (2-13mm)	4.37"	4.80"	1.81"
CAT40-NPU13-130U	CT40	3/32-1/2" (2-13mm)	5.40"	5.83"	1.81"
CAT50-NPU8-80U	CT50	0-5/16" (0-8mm)	3.25"	3.52"	1.36"
CAT50-NPU13-90U	CT50	3/32-1/2" (2-13mm)	3.82"	4.26"	1.81"

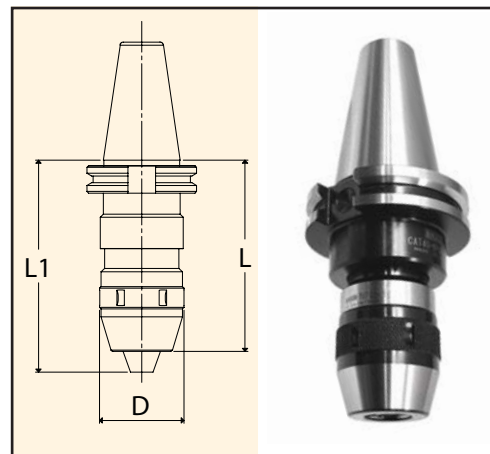

BT30/40/50 Taper

Part Number	Taper	Capacity	L	L1	D
BT30-NPU8-70	BT30	0-5/16" (0-8mm)	3.01"	3.29"	1.36"
BT30-NPU13-95	BT30	3/32-1/2" (2-13mm)	4.02"	4.45"	1.81"
BT40-NPU8-70	BT40	0-5/16" (0-8mm)	3.01"	3.29"	1.36"
BT40-NPU13-80	BT40	3/32-1/2" (2-13mm)	3.39"	3.82"	1.81"
BT50-NPU13-90	BT50	3/32-1/2" (2-13mm)	3.82"	4.26"	1.81"

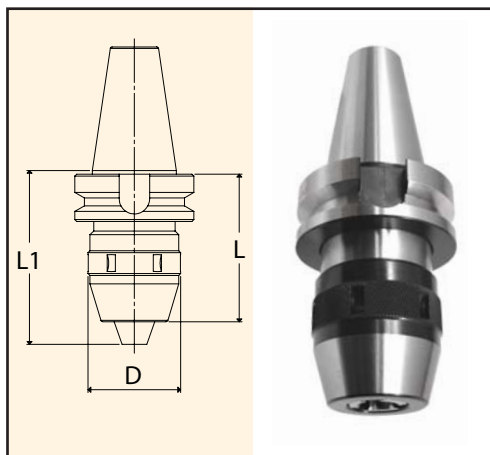

Accessories:



Drill Chuck Wrench
Page 89



Replacement Drill Chuck
Page 89



Replacement Jaws
Page 89

NMTB, HSK and Straight Shank Integral Keyless Drill Chucks

- Compact design and small head prevent drill slippage during operation
- Balanced to 12,000RPM
- High precision .0005" or better runout at 4xD
- Coolant-thru capable

Please note that the maximum RPM listed in our catalog may vary depending on the toolholder shank, weight, balanceability and the G rating.



TIR: minimal



Speed: up to 12,000 rpm



Set-up: quick and easy



Coolant-thru: available



Drilling
★ ★ ★ ★ ★



Reaming
★ ★ ★ ★ ★

NMTB40/50

Part Number	Taper	Capacity	L	L1	D
NMTB40-NPU8-76	NMTB40	0-5/16" (0-8.0mm)	3.25"	3.52"	1.36"
NMTB40-NPU13-86	NMTB40	3/32-1/2" (2-13.0mm)	3.62"	4.06"	1.81"
NMTB50-NPU13-86	NMTB50	3/32-1/2" (2-13.0mm)	3.62"	4.06"	1.81"

NMTB shanks are suitable for use with Erickson QC spindles.

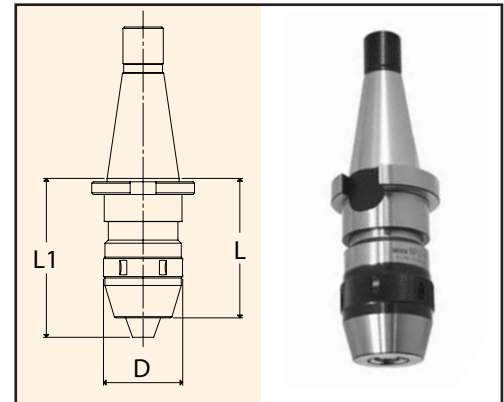

HSK40A/63A/100A

Part Number	Taper	Capacity	L	L1	D
HSK40A-NPU8-114	HSK40A	0-5/16" (0-8.0mm)	4.48"	4.76"	1.52"
HSK63A-NPU13C-135	HSK63A	3/32-1/2" (2-13.0mm)	5.59"	6.03"	1.81"
HSK100A-NPU13C-145	HSK100A	3/32-1/2" (2-13.0mm)	5.98"	6.42"	1.81"

Coolant tube and coolant tube wrench are not included. See page 89 for details.

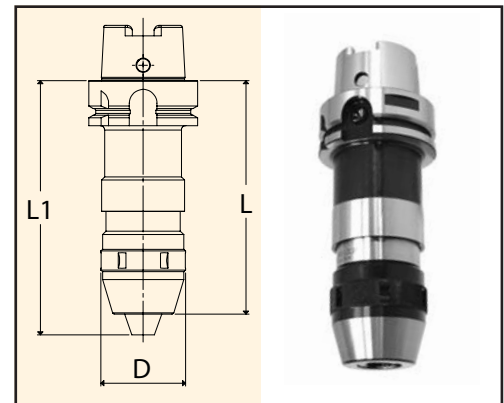

Straight Shank

Part Number	Capacity	D	D1	L	L1
D1.1/4-NPU13-6.23	3/32-1/2" (2-13.0mm)	1.92"	1.1/4"	6.23"	2.44"
D1.1/2-NPU13-6.35	3/32-1/2" (2-13.0mm)	1.92"	1.1/2"	6.35"	2.75"

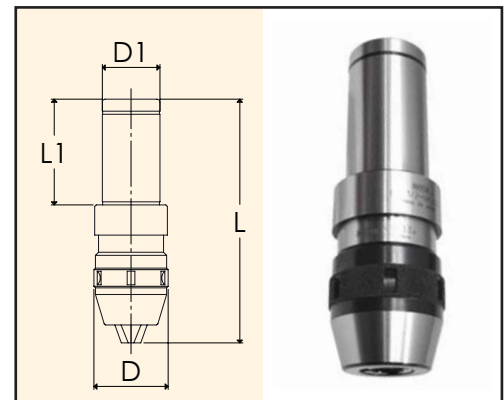

Accessories:



Drill Chuck Wrench
Page 89



Replacement Drill Chuck
Page 89



Replacement Jaws
Page 89

Drill Chuck Accessories

Replacement Wrench for Drill Chuck

Part Number	Description
NPU8-SPAN	Fits 5/16" (8.0mm) chucks
NPU13-SPAN	Fits 1/2" (13.0mm) chucks

Note: The wrench is not included with the holder, but sold separately.



Replacement Drill Chuck

Part Number	Description
9NPU-8	Replacement 1/4" Chuck
9NPU-13	Replacement 1/2" Chuck



Replacement Jaws for Drill Chuck

Part Number	Description
SP08062	Jaw Set for 1/4" Chuck
SP13062	Jaw Set for 1/2" Chuck



Coolant Tube Wrench for HSK holders

Part Number	Description
HSK63-WRENCH	Wrench for HSK63 Coolant Tube
HSK40-WRENCH	Wrench for HSK40 Coolant Tube
HSK100-WRENCH	Wrench for HSK100 Coolant Tube

Coolant tube wrenches are needed to remove or install coolant tubes in HSK toolholders



Coolant Tube HSK holders

Part Number	Description
HSK63-TUBE	Coolant tube for HSK63 Holders
HSK40-TUBE	Coolant tube for HSK40 Holders
HSK100-TUBE	Coolant tube for HSK100 Holders



CAT and BT Jacobs Taper Holders

CAT40/50

Part Number	Taper	JT Size	L	D
C4003-0002-1.61	CT40	JT#2	1.61"	.560"
C4003-0003-1.58	CT40	JT#3	1.58"	.812"
C4003-0004-1.49	CT40	JT#4	1.49"	1.13"
C4003-0006-1.61	CT40	JT#6	1.61"	.677"
C4003-0033-1.61	CT40	JT#33	1.61"	.625"
C5003-0002-1.61	CT50	JT#2	1.61"	.560"
C5003-0003-1.58	CT50	JT#3	1.58"	.812"
C5003-0004-1.49	CT50	JT#4	1.49"	1.13"
C5003-0006-1.61	CT50	JT#6	1.61"	.677"
C5003-0033-1.61	CT50	JT#33	1.61"	.625"

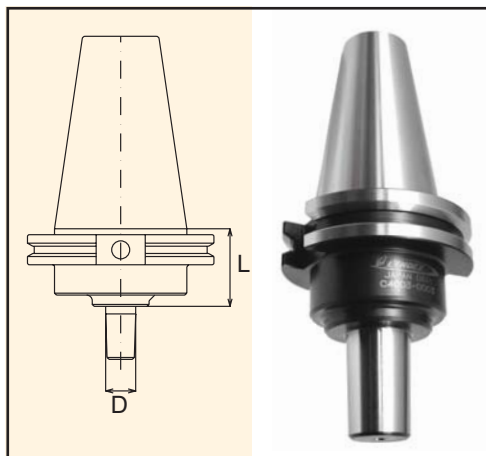

BT30/40/50

Part Number	Taper	JT Size	L	D
B3003-0001-1.06	BT30	JT#1	1.06"	.385"
B3003-0002-1.02	BT30	JT#2	1.02"	.560"
B3003-0003-0.98	BT30	JT#3	0.98"	.812"
B3003-0006-1.02	BT30	JT#6	1.02"	.677"
B3003-0033-1.02	BT30	JT#33	1.02"	.625"
B4003-0002-1.61	BT40	JT#2	1.61"	.560"
B4003-0003-1.57	BT40	JT#3	1.57"	.812"
B4003-0006-1.61	BT40	JT#6	1.61"	.677"
B4003-0033-1.61	BT40	JT#33	1.61"	.625"
B5003-0002-1.61	BT50	JT#2	1.61"	.560"
B5003-0003-1.57	BT50	JT#3	1.57"	.812"
B5003-0004-1.49	BT50	JT#4	1.49"	1.13"
B5003-0006-1.61	BT50	JT#6	1.61"	.677"
B5003-0033-1.61	BT50	JT#33	1.61"	.625"

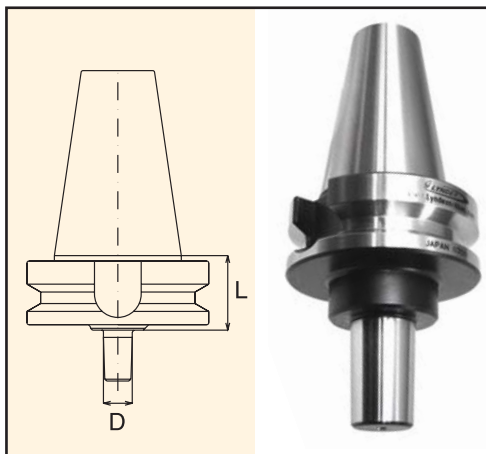

Accessories:



Jacobs Brand Drill Chuck
Page 92



Replacement Key
Page 92

NMTB and R8 Jacobs Taper Holders

NMTB30/40/50

Part Number	Taper	JT Size	L	D
N3003-0001-0.63	NMTB30	JT#1	0.63"	.385"
N3003-0002-0.59	NMTB30	JT#2	0.59"	.560"
N3003-0003-0.55	NMTB30	JT#3	0.55"	.812"
N3003-0006-0.59	NMTB30	JT#6	0.59"	.677"
N3003-0033-0.59	NMTB30	JT#33	0.59"	.625"
N4003-0001-0.69	NMTB40	JT#1	0.69"	.385"
N4003-0002-0.65	NMTB40	JT#2	0.65"	.560"
N4003-0003-0.61	NMTB40	JT#3	0.61"	.812"
N4003-0006-0.65	NMTB40	JT#6	0.65"	.677"
N4003-0033-0.65	NMTB40	JT#33	0.65"	.625"
N5003-0002-1.34	NMTB50	JT#2	1.34"	.560"
N5003-0003-1.30	NMTB50	JT#3	1.30"	.812"
N5003-0004-1.22	NMTB50	JT#4	1.22"	1.13"
N5003-0006-1.34	NMTB50	JT#6	1.34"	.677"
N5003-0033-1.34	NMTB50	JT#33	1.34"	.625"

NMTB shanks are suitable for use with Erickson QC spindles.

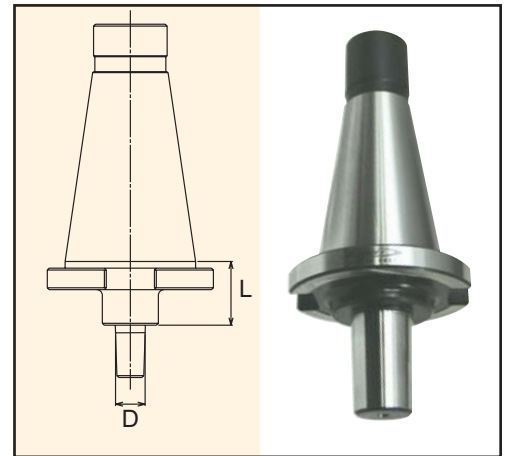

R8

Part Number	Taper	JT Size	L	D
870-001-0.13	R8	JT#1	0.13"	.385"
870-002-0.13	R8	JT#2	0.13"	.560"
870-003-0.13	R8	JT#3	0.13"	.812"
870-006-0.13	R8	JT#6	0.13"	.677"
870-033-0.13	R8	JT#33	0.13"	.625"

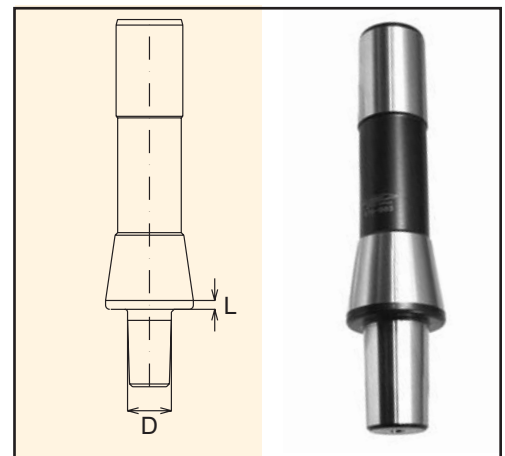

Accessories:



Jacobs Brand Drill Chuck
Page 92



Replacement Key
Page 92

Jacobs Drill Chucks Accessories

Jacobs Brand Drill Chuck

Part Number	Range	Fits Taper	Description
8-1/2N	0 - 1/4"	JT#2	Heavy Duty Ball Bearing Chuck
100-J2	0 - 3/8"	JT#2	High Precision Keyless Chuck
100-J33	0 - 3/8"	JT#33	High Precision Keyless Chuck
11N	0 - 3/8"	JT#2	Heavy Duty Ball Bearing Chuck
130-J2	1/32 - 1/2"	JT#2	High Precision Keyless Chuck
130-J33	1/32 - 1/2"	JT#33	High Precision Keyless Chuck
130-J6	1/32 - 1/2"	JT#6	High Precision Keyless Chuck
130-JT2	1/32 - 1/2"	JT#2	High Precision High Torque Keyless Chuck
130-JT33	1/32 - 1/2"	JT#33	High Precision High Torque Keyless Chuck
130-JT6	1/32 - 1/2"	JT#6	High Precision High Torque Keyless Chuck
14N	0 - 1/2"	JT#3	Heavy Duty Ball Bearing Chuck
160-J6	1/8 - 5/8"	JT#6	High Precision Keyless Chuck
160-JT6	1/8 - 5/8"	JT#6	High Precision High Torque Keyless Chuck
16N	1/8 - 5/8"	JT#3	Heavy Duty Ball Bearing Chuck
18N	1/8 - 3/4"	JT#4	Heavy Duty Ball Bearing Chuck
34-02	0 - 1/2"	JT#2	Heavy Duty Plain Bearing Chuck
34-06	0 - 1/2"	JT#6	Heavy Duty Plain Bearing Chuck
34-33	0 - 1/2"	JT#33	Heavy Duty Plain Bearing Chuck

Note: All high precision, high torque chucks come with a wrench.



Replacement Key

Part Number	Description
K-3	Key for plain bearing chuck



End Mill Holders
ERTG/DA Collet Chucks
Shell Mill Holders
Drill Chucks

CAT and BT Morse Taper Holders

- Balanced to 12,000RPM
- Coolant-thru capable



TIR: minimal



Speed: up to 12,000 rpm



Set-up: quick and easy



Coolant-thru: available



Drilling

★★★★★



Reaming

★★★★★

Please note that the maximum RPM listed in our catalog may vary depending on the toolholder shank, weight, balanceability and the G rating.

CAT 40/50

Part Number	Taper	Size	L	D	D1
C4004-0001-1.75	CT40	MT#1	1.75"	.475"	1.00"
C4004-0002-2.36	CT40	MT#2	2.36"	.700"	1.25"
C4004-0003-3.00	CT40	MT#3	3.00"	.938"	1.57"
C4004-0004-3.54	CT40	MT#4	3.54"	1.23"	1.97"
C5004-0002-1.75	CT50	MT#2	1.75"	.700"	1.25"
C5004-0003-1.75	CT50	MT#3	1.75"	.938"	1.57"
C5004-0004-3.00	CT50	MT#4	3.00"	1.23"	1.97"
C5004-0005-4.13	CT50	MT#5	4.13"	1.75"	2.75"

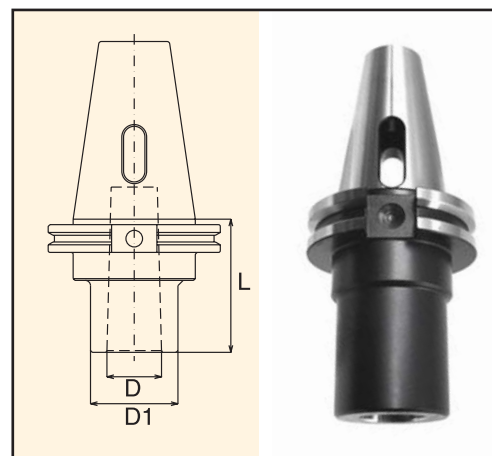

BT 30/40/50

Part Number	Taper	Size	L	D	D1
B3004-0001-1.75	BT30	MT#1	1.75"	.475"	1.00"
B3004-0002-2.36	BT30	MT#2	2.36"	.700"	1.25"
B4004-0001-1.75	BT40	MT#1	1.75"	.475"	1.00"
B4004-0002-2.36	BT40	MT#2	2.36"	.700"	1.25"
B4004-0003-3.00	BT40	MT#3	3.00"	.938"	1.57"
B4004-0004-3.54	BT40	MT#4	3.54"	1.23"	1.97"
B5004-0002-1.75	BT50	MT#2	1.75"	.700"	1.25"
B5004-0003-1.75	BT50	MT#3	1.75"	.938"	1.57"
B5004-0004-3.00	BT50	MT#4	3.00"	1.23"	1.97"
B5004-0005-4.13	BT50	MT#5	4.13"	1.75"	2.75"

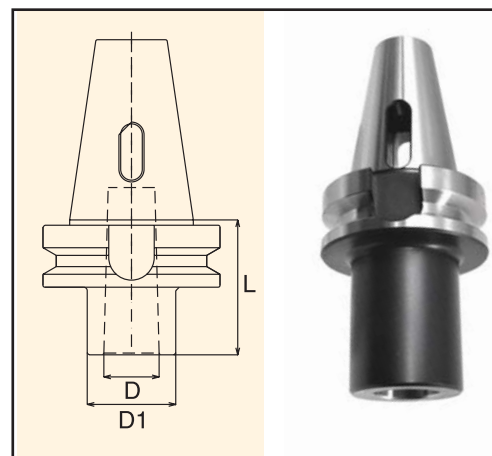

NMTB and R8 Morse Taper Holders

- Balanced to 12,000RPM
- Coolant-thru capable



TIR: minimal



Drilling
★★★★☆



Speed: up to 12,000 rpm



Reaming
★★★★☆



Set-up: quick and easy



Coolant-thru: available

Please note that the maximum RPM listed in our catalog may vary depending on the toolholder shank, weight, balanceability and the G rating.

NMTB 30/40/50

Part Number	Taper	Size	L	D	D1
N3004-0001-1.00	NMTB30	MT#1	1.00"	0.48"	1.00"
N3004-0002-2.13	NMTB30	MT#2	2.13"	0.70"	1.25"
N3004-0003-2.81	NMTB30	MT#3	2.81"	0.94"	1.57"
N4004-0001-0.94	NMTB40	MT#1	0.94"	0.48"	1.00"
N4004-0002-1.75	NMTB40	MT#2	1.75"	0.70"	1.25"
N4004-0003-2.25	NMTB40	MT#3	2.25"	0.94"	1.57"
N4004-0004-3.00	NMTB40	MT#4	3.00"	1.23"	1.97"
N5004-0002-1.88	NMTB50	MT#2	1.88"	0.70"	1.25"
N5004-0003-2.38	NMTB50	MT#3	2.38"	0.94"	1.57"
N5004-0004-3.25	NMTB50	MT#4	3.25"	1.23"	1.97"
N5004-0005-4.63	NMTB50	MT#5	4.63"	1.75"	2.75"

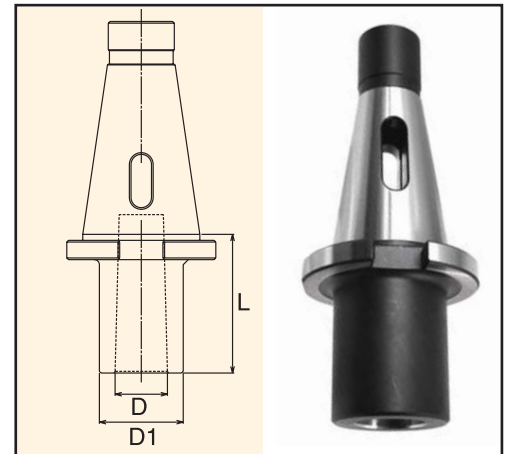

NMTB shanks are suitable for use with Erickson QC spindles.

R8

Part Number	Taper	Size	L	D	D1
840-001-0.44	R8	MT#1	0.44"	0.48"	1.00"
840-002-0.44	R8	MT#2	0.44"	0.70"	1.25"
840-003-2.56	R8	MT#3	2.56"	0.94"	1.57"

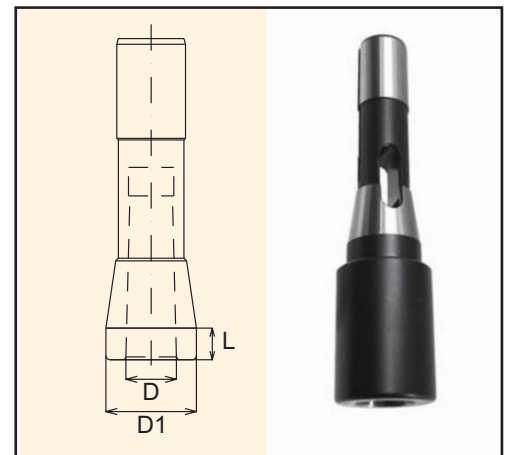

End Mill Holders

ERTG/DA Collet Chucks

Shell Mill Holders

Drill Chucks