



Milling Chucks

Shrink Fit Holders

SK Collet Chucks

VC Collet Chucks

MMC Collet Chucks

Accessories

Technical



Current Promotion

Scan
these
Live Tools
QR Codes



Featured Video

CustomTools™ / Live Tools

Live Tooling



Parts inventory, maintenance and repair, and rebuild services are available through Lyndex-Nikken.



- Official Mori Seiki Qualified Peripherals (MSQP) supplier
- Okuma Authorized Live Tool Supplier
- Nakamura Tome Authorized Live Tool Supplier



Lyndex-Nikken live tools are manufactured by Alps Tool Co. Ltd.

Maximize the Capabilities of Your Machine

Alps live tooling for Lyndex-Nikken offers the latest technology you can expect for turning operations. Designed and manufactured directly with engineers from leading builders in Japan, our live tools have features and benefits unmatched by the competition. Gears, bearings, seals, every part is built to provide the highest accuracy, rigidity and stability.

With more than 30 years of tooling engineering and manufacturing experience, Lyndex-Nikken live tooling will maximize the capabilities of your machine, and keep you far ahead of the global competition. We understand that exceptional quality is key to your business. Let the manufacturers who share your philosophy in producing live tools join you in doing what you do best - machining the highest quality parts.

Enhanced with Alps/Lyndex-Nikken live tooling, your machine will allow you to reduce cycle times, eliminate extra operations and achieve maximum efficiency.

Partner in the Okuma-THINC Advanced Research Center

Lyndex-Nikken works locally in the U.S. with Okuma at our Partners in THINC facility in Charlotte, NC. So, not only are our live tools custom-engineered specifically for Okuma Machines, we also work together to engineer optimal solutions for customer applications.

Live Tooling - Features and Technology

As an authorized OEM supplier to leading machine tool builders, Lyndex-Nikken live tools are designed and manufactured in conjunction with top engineers in Japan.

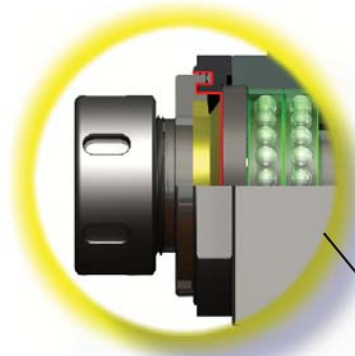

Protective Seals

- **Labyrinth Seals** - provide a high pressure multi barrier construction that prevents contaminants and coolant from entering the main chamber.

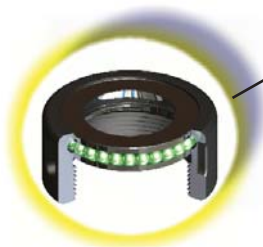

Eccentric Bearing Nut

- **Ground Eccentric Nut** - allows for fine accuracy and strong tool shank gripping capacity by preventing collet twisting or rocking.
- **Runout** - guarantee of under 5-micron repeatability at collet nose.

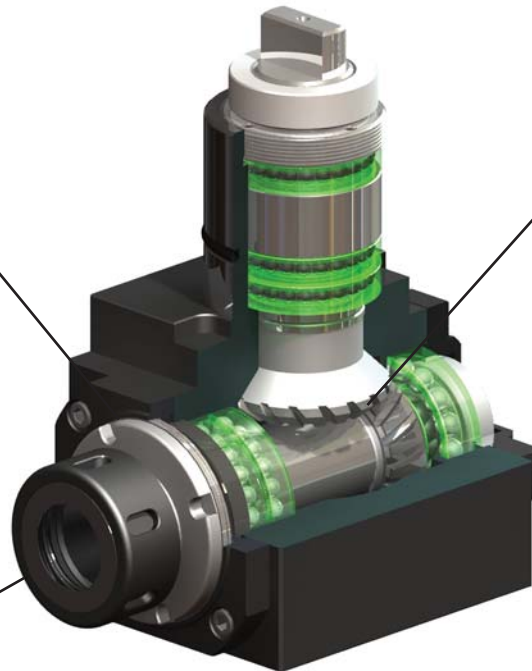





















Gears for Stability

- **Gear Pairing** - hand matched for each pair to minimize backlash.
- **Gear Design** - custom ground spiral bevel gear tooth design maximizes drive torque output and reduces tooth root stress allowing for more tool longevity.
- **Gear Equilibrium** - placement of bearings balance torque stress evenly through input/output shafts.









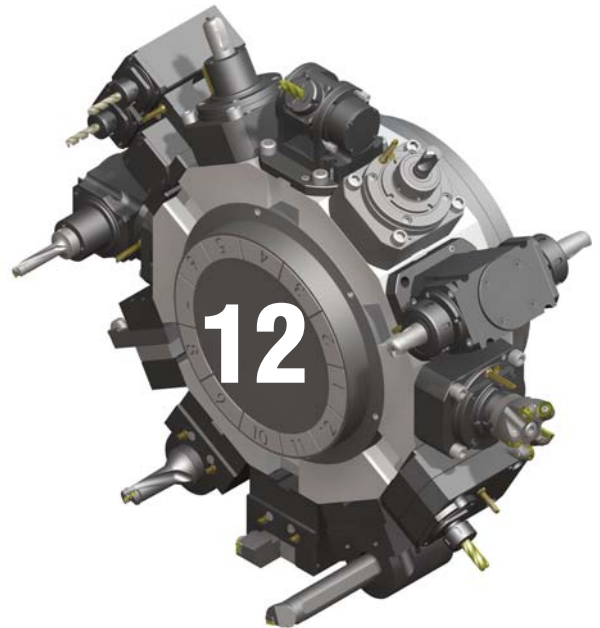

Tool Design and Engineering

- **Tool Body** - manufactured from the highest tensile and compression Nickel Chrome Molybdenum alloys.
- **Drive Shafts** - all features are ground on both the input and output Chrome Molybdenum drive shafts to assure proper torque transmission and precision concentricity.
- **Bearing Quality** - only the highest precision ABEC 7 angular contact bearings are used for smooth and high speed rotation.
- **Quality Control** - all live tools go through a vigorous 60-point final inspection to satisfy the highest expectations of live tool performance.

LIVE TOOLS - Straight				
	Part Number	Collet	Coolant	Speed
	Straight drill/milling unit			
	T32206	ER32		6000rpm
	T32213	ER40		6000rpm
	T32232	ER32		3000rpm
	T32478	ER32		6000rpm
T32234	ER40		6000rpm	
	2 spindles straight drill/milling unit			
	T32267	ER16		6000rpm
	Offset straight drill/milling unit			
	T32225	ER20		6000rpm
	High-grip straight drill/milling unit for milling chuck			
	T32219	20mm		3000rpm
	Straight milling unit for shell mill holder			
	T32268	22mm		3000rpm
	T32217	1"		3000rpm
	Straight drill/milling unit for weldon or whistle notch shank			
	T32227	20mm		3000rpm
	T32221	25mm		3000rpm
	T32223	1"		3000rpm
	Coromant Capto™ straight drill/milling unit			
	T32238	C4		6000rpm
LIVE TOOLS - Right Angle				
	Part Number	Collet	Coolant	Speed
	Right angle drill/milling unit			
	T32218	ER32		6000rpm
	T32207	ER32		6000rpm
	T32214	ER40		6000rpm
	T32233	ER32		6000rpm
T32235	ER40		6000rpm	
	Right angle double spindle drill/milling unit			
	T32216	ER32		6000rpm
	T32248	ER40		6000rpm
	2 spindles right angle drill/milling unit			
	T32264	ER16		6000rpm
	Adjustable right angle drill/milling unit			
	T32474	ER20		4000rpm
	High-grip right angle drill/milling unit for milling chuck			
	T32220	20mm		3000rpm
	Right angle milling unit for shell mill holder			
	T32269	22mm		3000rpm
	T32226	1"		3000rpm
	Right angle drill/milling unit for weldon or whistle notch shank			
	T32224	1"		3000rpm
	T32228	20mm		3000rpm
	T32222	25mm		3000rpm
	Coromant Capto™ right angle drill/milling unit			
	T32239	C4		6000rpm
	2T3200266	C4		3000rpm

Mori Seiki 12-Station, NL, NT4000 and NT5000 Series



STATIC TOOLS				
	Part Number	Output	Type	Coolant
	OD CUTTING HOLDER			
	T00201	1.5"	both sides	
	T00199	2"	both sides	
	T00210*	1.18"	Y double	
	CUT OFF HOLDER			
	T00198	1.02"	Cut-off holder, right hand	
	FACE AND ID CUTTING HOLDER			
	T03014	1.5"	Face and ID cutting	
	T03013	2"	Face and ID cutting	
	BORING BAR HOLDER			
	T10101*	1.5"	Boring bar holder	
	T10102*	2"	Boring bar holder	
	T13130*	1.5"	Combination holder	
	T10100*	1.25"	Boring bar, both sides	
	BORING BAR HOLDER - WITH SLOT			
	T10142*	2"	Boring bar holder w/slot	
	T10143*	1.5"	Boring bar holder w/slot	
	OD AND ID CAPTO HOLDER			
	T12068	C5	ID Capto holder	
	T12069	C5	ID both side Capto	
	T00209	C5	OD both side Capto	
	T00208	C5	OD Capto holder	

*For Mori Seiki 12-station NL Series only.

Milling Chucks

Shrink Fit Holders

SK Collet Chucks

VC Collet Chucks

MMC Collet Chucks





Accessories



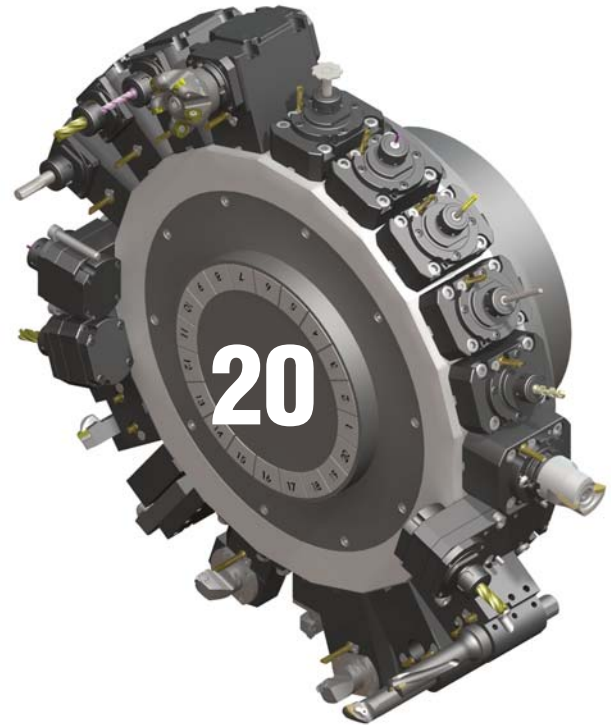



Technical









CustomTools™ / Live Tools

Mori Seiki 20-Station, NL, DuraTurn, NZ and NT3000 Series











































LIVE TOOLS - Straight				
	Part Number	Collet	Coolant	Speed
	Straight drill/milling unit			
	T32254	ER20		6000rpm
	T32274	ER25		6000rpm
	T32475	ER32		6000rpm
	T32286	ER16		10000rpm
	T32287	ER20		6000rpm
	Offset straight drill/milling unit			
	T32279	ER20		6000rpm
	Straight milling unit for shell mill holder			
	T32280	22mm		2000rpm
	Coromant Capto™ straight drill/milling unit			
	T32290	C3		6000rpm

LIVE TOOLS - Right Angle				
	Part Number	Collet	Coolant	Speed
	Right angle drill/milling unit			
	T32288	ER20		6000rpm
	T32255	ER20		6000rpm
	T32275	ER25		6000rpm
	T32476	ER32		6000rpm
	T32293	ER16		10000rpm
	Right angle double spindle drill/milling unit			
	T32271	ER20		6000rpm
	T32276	ER25		6000rpm
	Adjustable right angle drill/milling unit			
	T32289	ER16		4000rpm
	Right angle milling unit for shell mill holder			
	T32292	22mm		2000rpm
	Coromant Capto™ right angle drill/milling unit			
	T32291	C3		6000rpm

STATIC TOOLS				
	Part Number	Output	Type	Coolant
	OD CUTTING HOLDER			
	T00234	1.5"	OD cutting, short	
	T00235	1.5"	OD cutting, long	
	OD CUTTING HOLDER - BOTH SIDES			
	T00250*	1.5"	short, both sides	
	T00249*	1.5"	long, both sides	
	FACE AND ID CUTTING HOLDER			
	T03018	1.5"	Face and ID cutting	
	CUT-OFF HOLDER			
	T00252	0.77"	boring bar, right hand	
	BORING BAR HOLDER			
	T10119	1.25"	Boring bar holder	
	T10139*	1"	both sides	
	COMBINATION HOLDER			
	T13135	1.25"	Combination holder	
	OD AND ID CAPTO HOLDER			
	T12074	C4	OD Capto holder	
	T12075	C4	ID Capto holder	
	AC4-AMS100-WA	C4	OD both sides	
	AC4-AMS100-WB	C4	ID both sides	





*Not Suitable for Mori Seiki DuraTurn Series.





Part No./Description		Coolant-Thru	High-Speed	Nakamura Tome Models					
Lyndex-Nikken	Nakamura			NTJ	NTM3	NTY3	SC-150II	SC-200L	SC-250
NK103-11000 X-AXIS, 3600rpm	AR1390								
NK103-10000 Z-AXIS, 3600rpm	AR1393								
NK103-13000 X-AXIS, 6000rpm	AC1310								
NK103-12000 Z-AXIS, 6000rpm	AC1313								
NK103-15000 Z-AXIS, 3600rpm	AG1313								
NK103-16000 Z-AXIS, 6000rpm	AG1393								
NK103-5K000 X-AXIS, 6000rpm	-								
NK103-6H000 Z-AXIS, 6000rpm	-								
NK103-6J000 Z-AXIS, 6000rpm	-								
NKA01-20000 Z-AXIS, 6000rpm	F26333								
NKA01-13000 X-AXIS, 6000rpm	C26330								
NKA01-12000 Z-AXIS, 6000rpm	C26333								
NKA00-11000 X-AXIS, 4000rpm	D22310								
NKA00-10000 Z-AXIS, 4000rpm	D22313								
NK105-37000 X-AXIS, 3600rpm	R2390								
NK105-36000 Z-AXIS, 3600rpm	R2393								
NK105-49000 X-AXIS, 6000rpm	-								
NK105-33000 Z-AXIS, 6000rpm	-								



All Nakamura live tools can be used in all positions on all turrets (for main or sub) for each given machine model.

Milling Chucks
Shrink Fit Holders
SK Collet Chucks
VC Collet Chucks
MMC Collet Chucks
Accessories
Technical
CustomTools™ / Live Tools

Okuma Live Tooling - Captain Series Lathes

Captain Series L370-M and Genos L300-M				
	Lyndex-Nikken Part No.	Collet	Coolant	Speed
OD drill/milling unit				
	OK101-14000	ER32		4500rpm
	OK101-67000	ER40		4500rpm
Face drill/milling unit				
	OK101-13000	ER32		4500rpm
	OK101-72000	ER32		4500rpm
Adjustable holder				
	OK101-73000	ER20		4000rpm

Captain Series L370-MW				
	Lyndex-Nikken Part No.	Collet	Coolant	Speed
Face drill/milling unit - main				
	OK109-13001	ER32		4500rpm
Face drill/milling unit - sub				
	OK109-14001	ER32		4500rpm
Face drill/milling unit - double				
	OK109-15001	ER32		4500rpm
OD drill/milling unit				
	OK101-14000	ER32		4500rpm
	OK102-18000	ER40		3000rpm
	OK102-23000	ER32		4500rpm

Captain Series L470-M				
	Lyndex-Nikken Part No.	Collet	Coolant	Speed
OD drill/milling unit				
	OK102-17000	ER40		3000rpm
	OK102-22000	ER40		3000rpm
Adjustable holder				
	OK102-24000	ER20		4000rpm

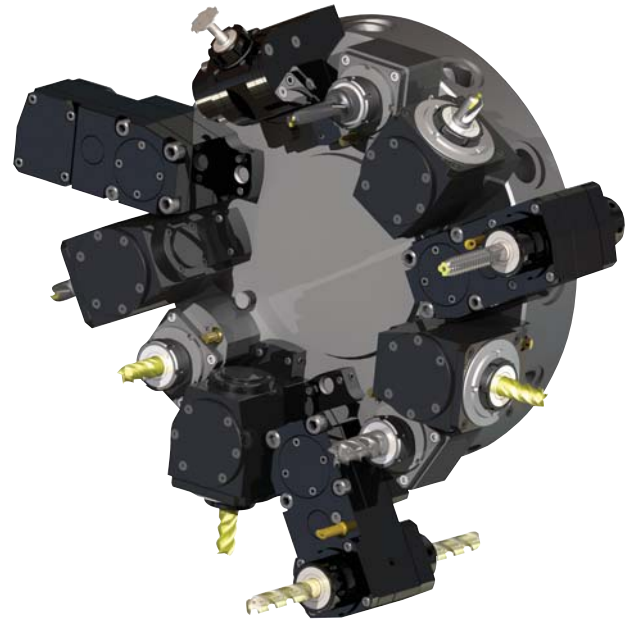

Milling Chucks

Shrink Fit Holders

SK Collet Chucks

VC Collet Chucks





MMC Collet Chucks











Accessories

Technical



CustomTools™ / Live Tools



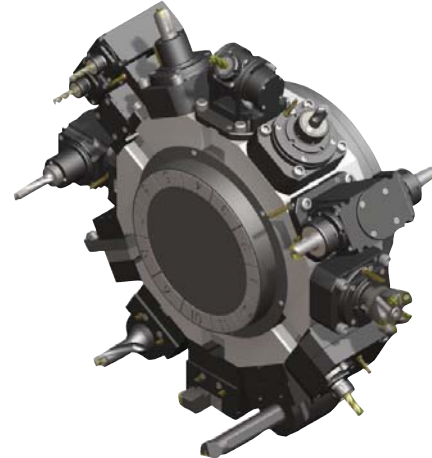

Okuma Live Tooling - LB EX Series Lathes

LB2000/2500/3000EX Series and Genos L300-MW				
	Lyndex-Nikken Part No.	Collet	Coolant	Speed
	OD drill/milling unit			
	OKA00-19000	ER32		6000rpm
	OKA00-28000	ER32		3000rpm
	Face drill/milling unit			
	OKA00-20000	ER32		6000rpm
	OKA00-24000	ER32		3000rpm
	Twin spindle drill/milling unit			
	OKA00-21001	ER32		6000rpm

LB2000/2500/3000EX Series - Static Tools				
	Lyndex-Nikken Part No.	Output	Coolant	Interface
	Boring bar holder (1.25")			
	OK126-40000	1.25"		Bolt
	Boring bar holder (1.25")			
	OK126-41000	1.25"		Bolt
	Boring bar holder (1.5")			
	OK126-50000	1.5"		Bolt
	Boring bar holder (1.5")			
	OK126-51000	1.5"		Bolt
	OD cutting holder (1" and 3/4")			
	OK126-42000	1"		Bolt
	OD cutting holder (1")			
	OK126-52000	1"		Bolt
	OD cutting holder (1" and 3/4")			
	OK126-43000	1"		Bolt
	ID cutting holder (1")			
	OK126-53000	1"		Bolt



LB4000EX Series				
	Lyndex-Nikken Part No.	Collet	Coolant	Speed
	OD drill/milling unit			
	OKA01-13000	ER40		6000rpm
	Face drill/milling unit			
	OKA01-14000	ER40		6000rpm

LB4000EX Series - Static Tools				
	Lyndex-Nikken Part No.	Output	Coolant	Interface
	Boring bar holder (1.5")			
	OK126-60000	1.5"		Bolt
	Boring bar holder (1.5")			
	OK126-61000	1.5"		Bolt
	OD cutting holder (1")			
	OK126-64000	1"		Bolt
	ID cutting holder (1")			
	OK126-65000	1"		Bolt

Milling Chucks

Shrink Fit Holders

SK Collet Chucks

VC Collet Chucks

MMC Collet Chucks

Accessories

Technical

CustomTools™ / Live Tools