



End Mill Holders

ER/TG/DA Collet Chucks

Shell Mill Holders

Drill Chucks

Tap Holders

Stub, Boring, Blank



Current Promotion

Scan these QR Codes



Featured Video

Stub Mill Holder Features

Our Stub Mill Holders feature hardened and ground tapers, location shafts and arbor spacers to ensure clamping of cutting tools and rigid machining capability.

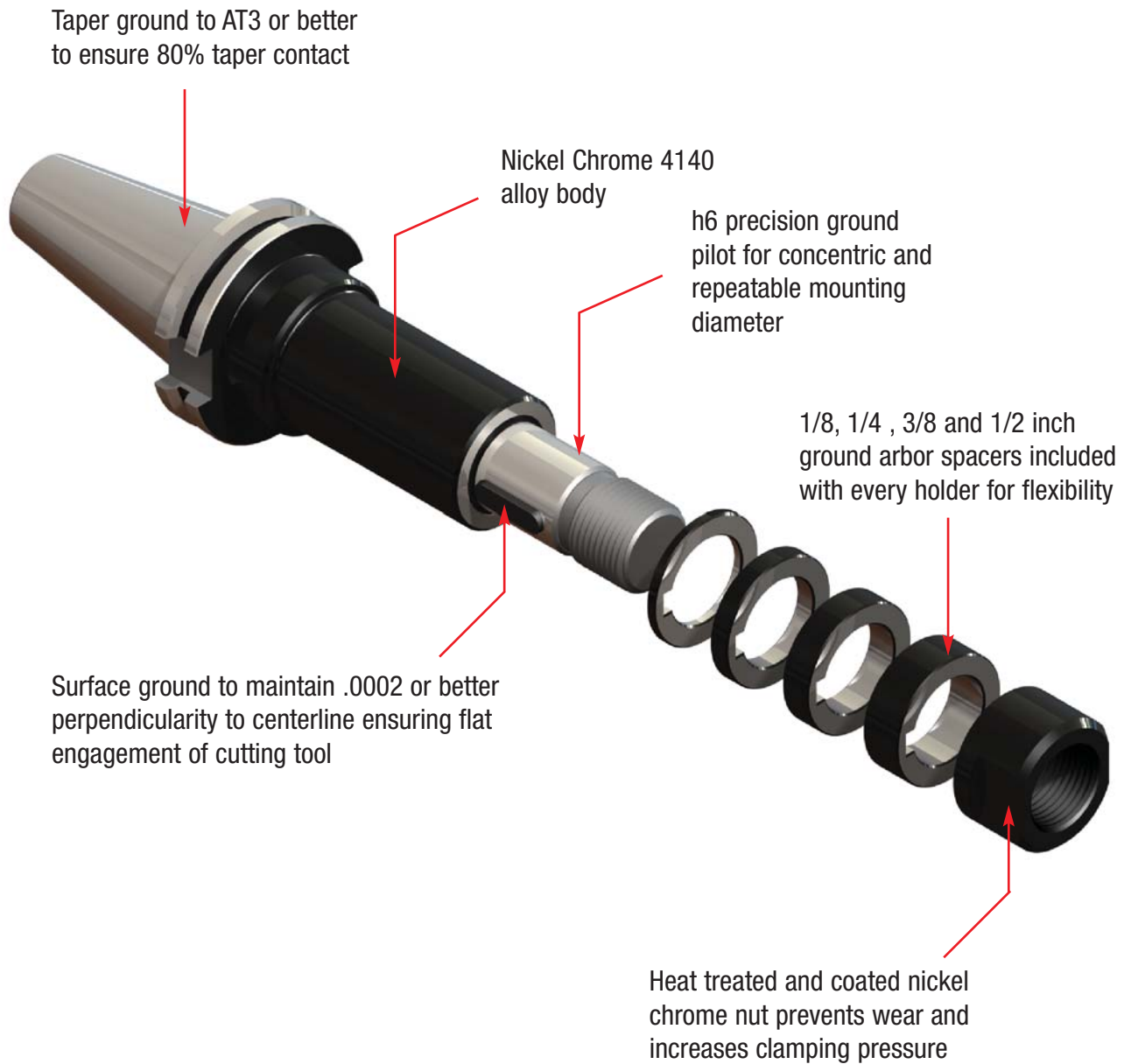

End Mill Holders
ERTG/DA Collet Chucks
Shell Mill Holders
Drill Chucks
Tap Holders
Stub, Boring, Blank

CAT and BT Stub Mill Holders

- Taper ground to AT3 or better to ensure 80% taper contact
- 1/8", 1/4", 3/8" and 1/2" ground arbor spacers included with every holder
- h6 precision ground pilot for concentric and repeatable mounting diameter

Please note that the maximum RPM listed in our catalog may vary depending on the toolholder shank, weight, balanceability and the G rating.



TIR: < .0002 run out along pilot



Speed: up to 15,000 rpm



Set-up: quick and easy



Coolant-thru: opt. not available

CAT40/50

Part Number	Taper	d	L	D	L1	Key Size
C4002-1000-6.17	CT40	1"	6.17"	1.50"	4.00"	1/4"
C4002-1250-6.29	CT40	1-1/4"	6.29"	1.75"	4.00"	5/16"
C4002-1500-6.60	CT40	1-1/2"	6.60"	2.12"	4.00"	3/8"
C5002-1000-6.17	CT50	1"	6.17"	1.50"	4.00"	1/4"
C5002-1250-6.28	CT50	1-1/4"	6.28"	1.75"	4.00"	5/16"
C5002-1500-6.60	CT50	1-1/2"	6.60"	2.12"	4.00"	3/8"

Note: 1/8", 1/4", 3/8" and 1/2" arbor spacers and securing nut included as standard with all listed toolholders.

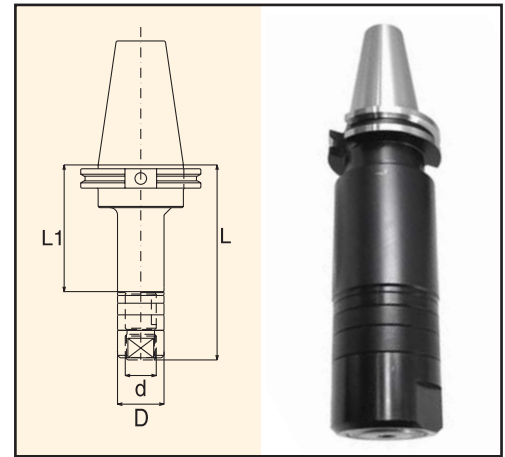

BT30/40/50

Part Number	Taper	d	L	D	L1	Key Size
B3002-0750-4.97	BT30	3/4"	4.97"	1.25"	3.00"	1/8"
B3002-1000-5.17	BT30	1"	5.17"	1.50"	3.00"	1/4"
B4002-1000-5.18	BT40	1"	5.18"	1.50"	3.00"	1/4"
B4002-1250-5.32	BT40	1-1/4"	5.32"	1.75"	3.00"	5/16"
B4002-1500-5.60	BT40	1-1/2"	5.60"	2.12"	3.00"	3/8"
B5002-1000-6.17	BT50	1"	6.17"	1.50"	4.00"	1/4"
B5002-1250-6.28	BT50	1-1/4"	6.28"	1.75"	4.00"	5/16"
B5002-1500-6.60	BT50	1-1/2"	6.60"	2.12"	4.00"	3/8"

Note: 1/8", 1/4", 3/8" and 1/2" arbor spacers and securing nut included as standard with all listed toolholders.

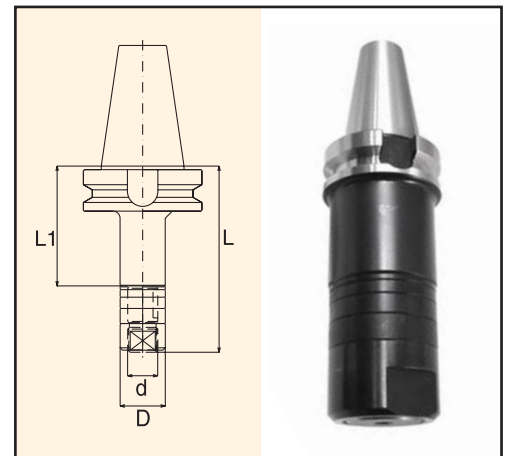

Accessories:



Replacement Nut
Page 123



Replacement Spacer
Page 123

NMTB and R8 Stub Mill Holders

- Taper ground to AT3 or better to ensure 80% taper contact
- 1/8", 1/4", 3/8" and 1/2" ground arbor spacers included with every holder
- h6 precision ground pilot for concentric and repeatable mounting diameter



TIR: < .0002 run out along pilot



Speed: up to 15,000 rpm



Set-up: quick and easy



Coolant-thru: opt. not available

Please note that the maximum RPM listed in our catalog may vary depending on the toolholder shank, weight, balanceability and the G rating.

NMTB30/40/50

Part Number	Taper	d	L	D	L1	Key Size
N3002-0750-4.97	NMTB30	3/4"	4.97"	1.25"	3.00"	1/8"
N3002-1000-5.18	NMTB30	1"	5.18"	1.50"	3.00"	1/4"
N3002-1250-5.28	NMTB30	1-1/4"	5.28"	1.75"	3.00"	5/16"
N4002-0750-5.00	NMTB40	3/4"	5.00"	1.25"	3.00"	1/8"
N4002-1000-5.18	NMTB40	1"	5.18"	1.50"	3.00"	1/4"
N4002-1250-5.28	NMTB40	1-1/4"	5.28"	1.75"	3.00"	5/16"
N4002-1500-5.62	NMTB40	1-1/2"	5.62"	2.12"	3.00"	3/8"
N5002-1000-6.18	NMTB50	1"	6.18"	1.50"	4.00"	1/4"
N5002-1250-6.28	NMTB50	1-1/4"	6.28"	1.75"	4.00"	5/16"
N5002-1500-6.60	NMTB50	1-1/2"	6.60"	2.12"	4.00"	3/8"

Note: 1/8", 1/4", 3/8" and 1/2" arbor spacers and securing nut included as standard with all listed toolholders. NMTB shanks are suitable for use with Erickson QC spindles.

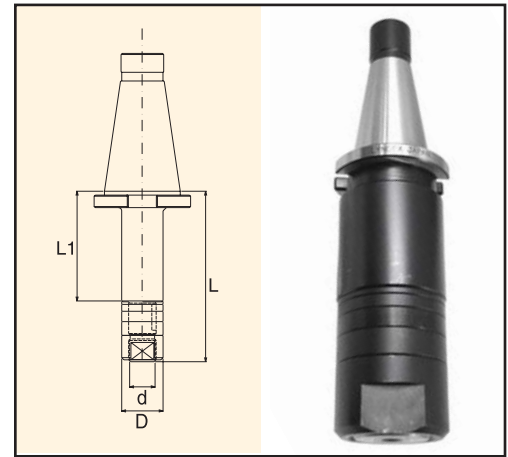

R8

Part Number	Taper	d	L	D	L1	Key Size
880-064-2.76	R8	1.00"	2.76"	1.50"	0.48"	1/4"
880-080-2.82	R8	1.25"	2.82"	1.75"	0.50"	5/16"

Note: 1/8", 1/4", 3/8" and 1/2" arbor spacers and securing nut included as standard with all listed toolholders.

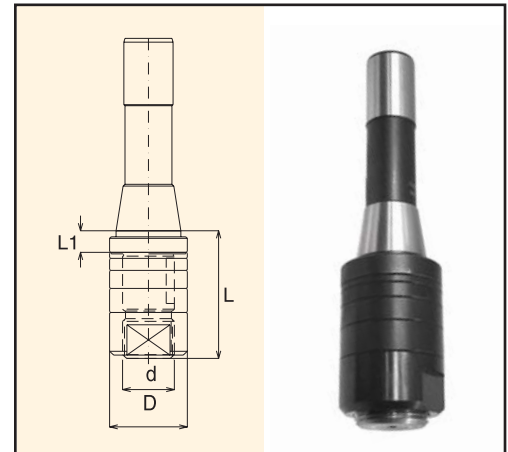

Accessories:



Replacement Nut
Page 123



Replacement Spacer
Page 123

End Mill Holders
ERT/G/DA Collet Chucks
Shell Mill Holders
Drill Chucks
Tap Holders
Stub, Boring, Blank

Accessories

Replacement Nut for Stub Mill Holders

Part Number	Description	Length of Nut
3/4-STUBNUT	3/4"	18 mm (0.70")
1-STUBNUT	1"	22.5 mm (0.88")
1-1/4-STUBNUT	1-1/4"	22.5 mm (0.88")
1-1/2-STUBNUT	1-1/2"	33.5 mm (1.31")



Replacement Spacer for Stub Mill Holders

Part Number	Description
SP3/4-1/8	1/8" Thick Spacer for 3/4" OD Holder
SP3/4-1/4	1/4" Thick Spacer for 3/4" OD Holder
SP3/4-3/8	3/8" Thick Spacer for 3/4" OD Holder
SP3/4-1/2	1/2" Thick Spacer for 3/4" OD Holder
SP1-1/8	1/8" Thick Spacer for 1" OD Holder
SP1-1/4	1/4" Thick Spacer for 1" OD Holder
SP1-3/8	3/8" Thick Spacer for 1" OD Holder
SP1-1/2	1/2" Thick Spacer for 1" OD Holder
SP1-1/4-1/8	1/8" Thick Spacer for 1-1/4" OD Holder
SP1-1/4-1/4	1/4" Thick Spacer for 1-1/4" OD Holder
SP1-1/4-3/8	3/8" Thick Spacer for 1-1/4" OD Holder
SP1-1/4-1/2	1/2" Thick Spacer for 1-1/4" OD Holder
SP1-1/2-1/8	1/8" Thick Spacer for 1-1/2" OD Holder
SP1-1/2-1/4	1/4" Thick Spacer for 1-1/2" OD Holder
SP1-1/2-3/8	3/8" Thick Spacer for 1-1/2" OD Holder
SP1-1/2-1/2	1/2" Thick Spacer for 1-1/2" OD Holder



CAT, BT and NMTB Boring Head Holders

- Taper ground to AT3 or better to ensure 80% taper contact
- Ground surfaces



TIR: < .0002 run out along pilot



Speed: up to 15,000 rpm



Set-up: quick and easy



Coolant-thru: opt. modification

Please note that the maximum RPM listed in our catalog may vary depending on the toolholder shank, weight, balanceability and the G rating.

CAT40/50

Part Number	Taper	Thread	L	L1	D
C40BH-0875-1.75	CT40	7/8"-20	1.75"	0.44"	1.75"
C40BH-1500-1.75	CT40	1-1/2"-18	1.75"	0.50"	2.96"
C50BH-0875-1.75	CT50	7/8"-20	1.75"	0.44"	1.75"
C50BH-1500-1.75	CT50	1-1/2"-18	1.75"	0.50"	2.96"

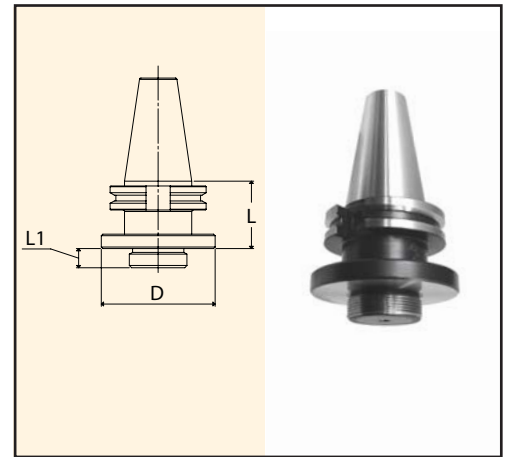

BT30/40/50

Part Number	Taper	Thread	L	L1	D
B30BH-0875-1.75	BT30	7/8"-20	1.75"	0.44"	1.75"
B30BH-1500-1.75	BT30	1-1/2"-18	1.75"	0.50"	2.96"
B40BH-0875-1.75	BT40	7/8"-20	1.75"	0.44"	1.75"
B40BH-1500-1.75	BT40	1-1/2"-18	1.75"	0.50"	2.96"
B50BH-0875-1.75	BT50	7/8"-20	1.75"	0.44"	1.75"
B50BH-1500-1.75	BT50	1-1/2"-18	1.75"	0.50"	2.96"

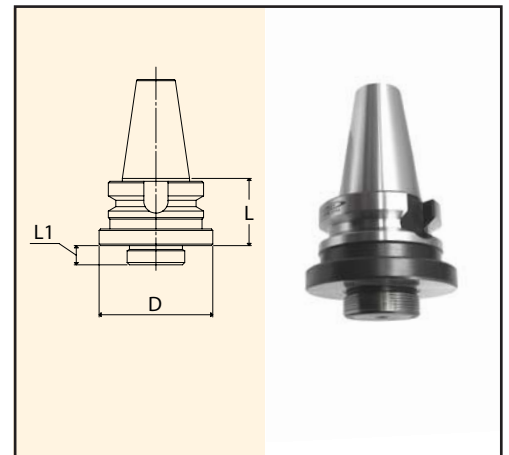

NMTB40/50

Part Number	Taper	Thread	L	L1	D
N40BH-0875-1.75	NMTB40	7/8"-20	1.75"	0.44"	1.75"
N40BH-1500-1.75	NMTB40	1-1/2"-18	1.75"	0.50"	2.96"
N50BH-0875-1.75	NMTB50	7/8"-20	1.75"	0.44"	1.75"
N50BH-1500-1.75	NMTB50	1-1/2"-18	1.75"	0.50"	2.94"

NMTB shanks are suitable for use with Erickson QC spindles.

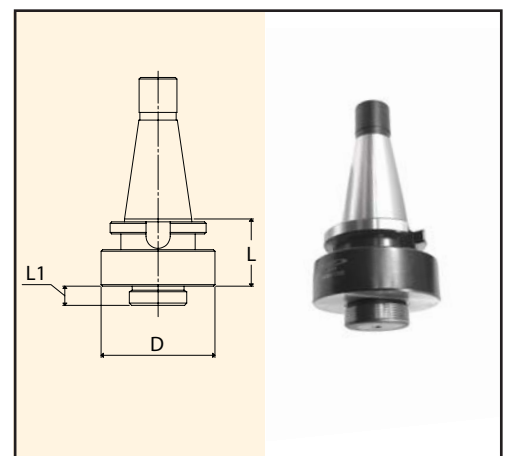

CAT and BT Blank Bars

- Taper ground to AT3 or better to ensure 80% taper contact
- Suitable for all applications – even deep boring
- Ground and hardened surfaces except projection of the toolholder



TIR: < .0002 run out along pilot



Speed: up to 15,000 rpm



Set-up: quick and easy



Coolant-thru: opt. modification

Please note that the maximum RPM listed in our catalog may vary depending on the toolholder shank, weight, balanceability and the G rating.

CAT40/50

Part Number	Taper	L	D
C4008-0013	CT40	13.00"	2.50"
C5008-0013	CT50	13.00"	3.88"

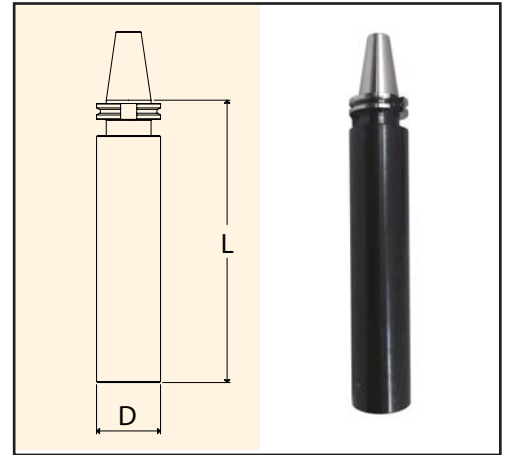

BT30/40/50

Part Number	Taper	L	D
B3008-0008	BT30	8.00"	2.25"
B4008-0013	BT40	13.00"	2.50"
B5008-0013	BT50	13.00"	3.88"

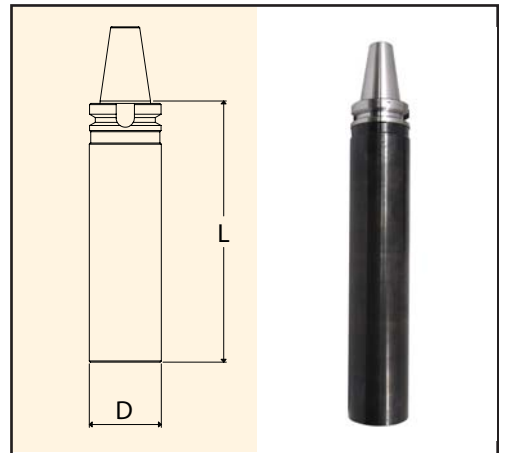

NMTB and HSK Blank Bars

NMTB40/50

Part Number	Taper	L	D
N4008-0013	NMTB40	13.00"	2.50"
N5008-0013	NMTB50	13.00"	3.88"

NMTB shanks are suitable for use with Erickson QC spindles.

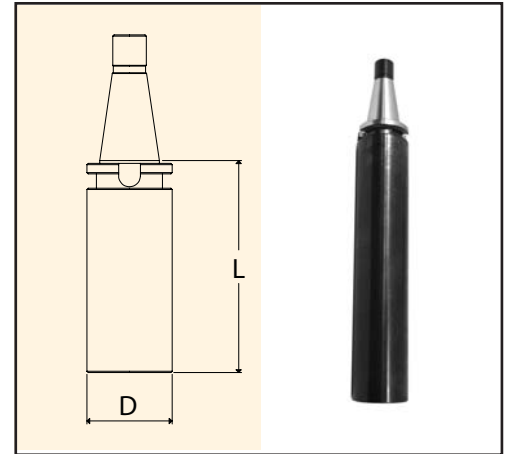

HSK40A/63A/100A

Part Number	Taper	L	D
HSK40A-BLANK-8.00	HSK40A	8.00"	2.00"
HSK63A-BLANK-13.00	HSK63A	13.00"	2.50"
HSK100A-BLANK-13.00	HSK100A	13.00"	3.75"

Note: Coolant tube and coolant tube wrench are not included.
Other HSK sizes are available as specials. Please contact us for more information.

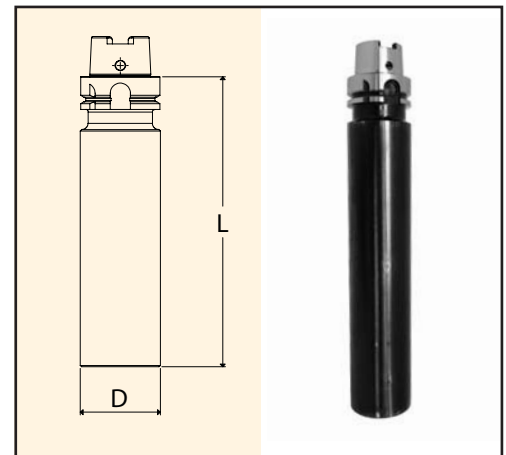

Coolant Tube Wrench for HSK Holders

Part Number	Description
HSK63-WRENCH	Wrench for HSK63 Coolant Tube
HSK40-WRENCH	Wrench for HSK40 Coolant Tube
HSK100-WRENCH	Wrench for HSK100 Coolant Tube

Coolant tube wrenches are needed to remove or install coolant tubes in HSK toolholders



Coolant Tube for HSK Holders

Part Number	Description
HSK63-TUBE	Coolant Tube for HSK63 Holders
HSK40-TUBE	Coolant Tube for HSK40 Holders
HSK100-TUBE	Coolant Tube for HSK100 Holders

