

## 5 Changing of cables, receptacles and air hose direction

There are two type of motor cover on which cables or receptacles direction can be changed.

### 5.1 Handling of two-directional-mounting motor cover

The attaching plate of receptacle has been fitted to the B-plane when the CNC rotary table is shipped, unless otherwise specified. The procedures of changing the attaching plate of receptacle and air hose are described hereunder.



1) Switch off main power of machine tool.



2) Remove the air coupler to stop the air supply.

3) Remove the receptacles and air hose.

4) Remove a blank plate in order for easy changing work.

5) Remove the attaching plate of receptacle.

6) Pull out the attaching plate and remove the air hose from inside. Remove four screws attaching the receptacle.

7) Change directions of receptacles and air hose and attach them to the attaching plate.

8) Fasten the attaching plate to motor cover.

9) Fasten the blank plate.

10) Connect the cables and air hose.

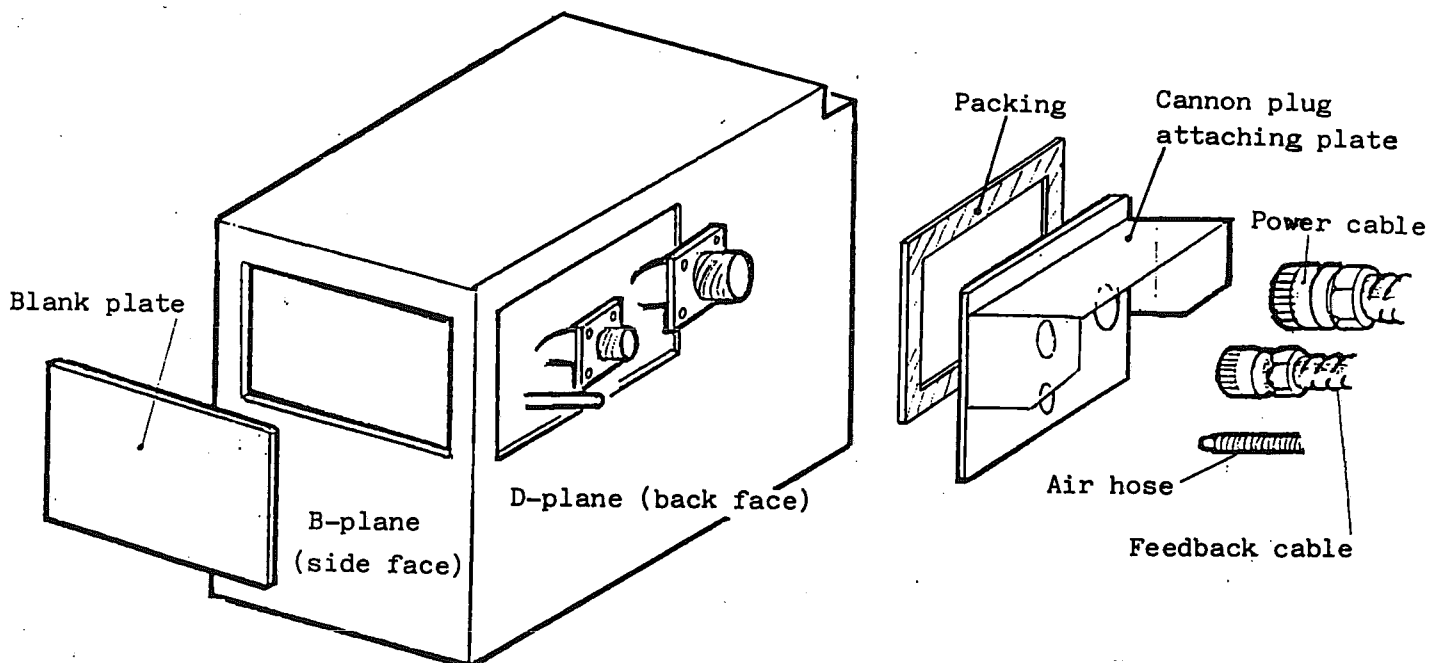

## 5.2 Handling of three-directional-mounting motor cover

The cables and air hose direction has been fitted to the B-direction when the CNC rotary table is shipped, unless otherwise specified. The procedures of changing direction are described hereunder.



1) Switch off main power of machine tool.



2) Remove the air coupler to stop the air supply.

3) Remove the receptacles and air hose at machine tool side.

4) Remove three-directional-mounting plate.

5) Change directions of three-directional-mounting plate and fasten it to the motor cover.

6) Connect the receptacles and air hose.

6 Layout of electric parts

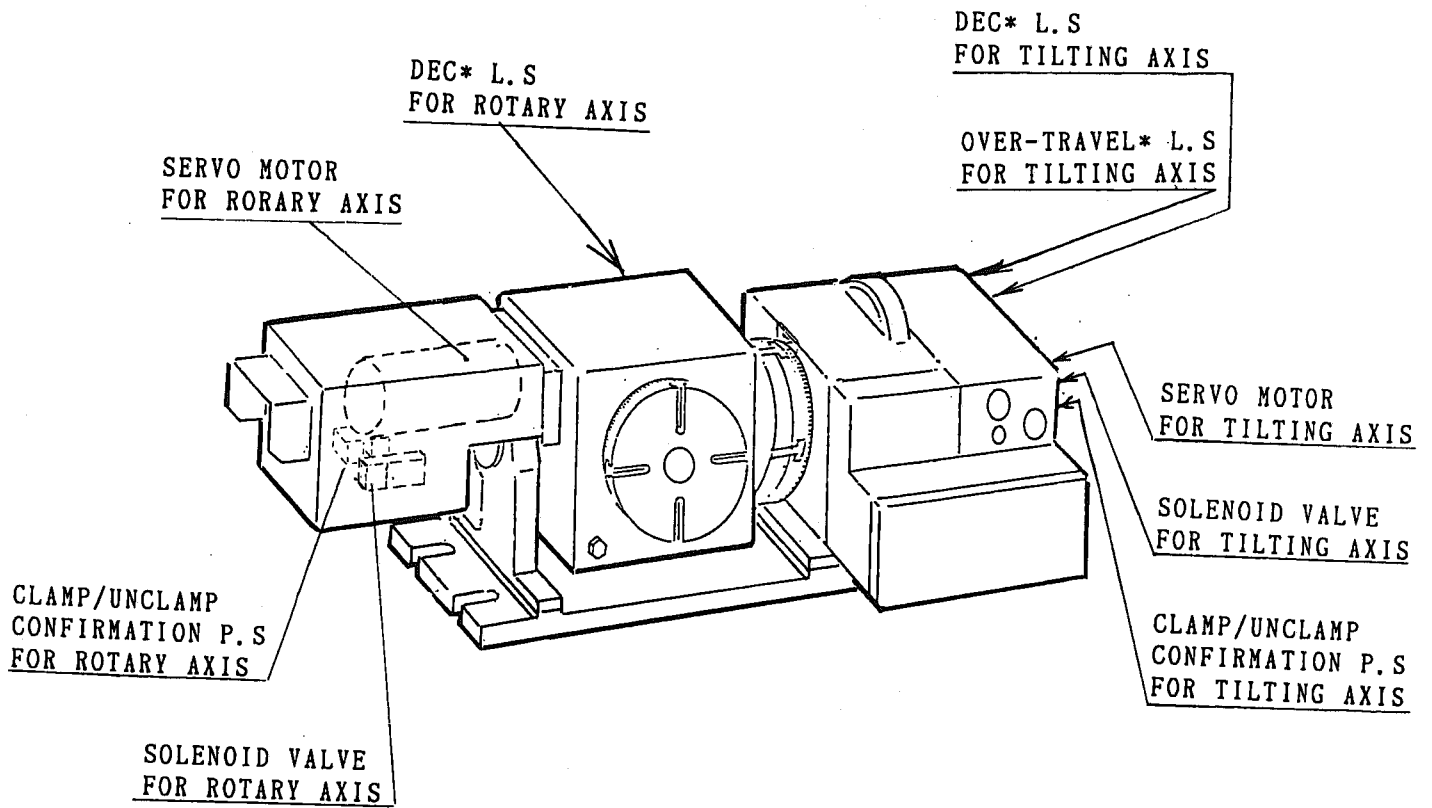

5AX-170 LAYOUT OF  
ELECTRIC PARTS  
TCZ-34001

7 Spare parts list

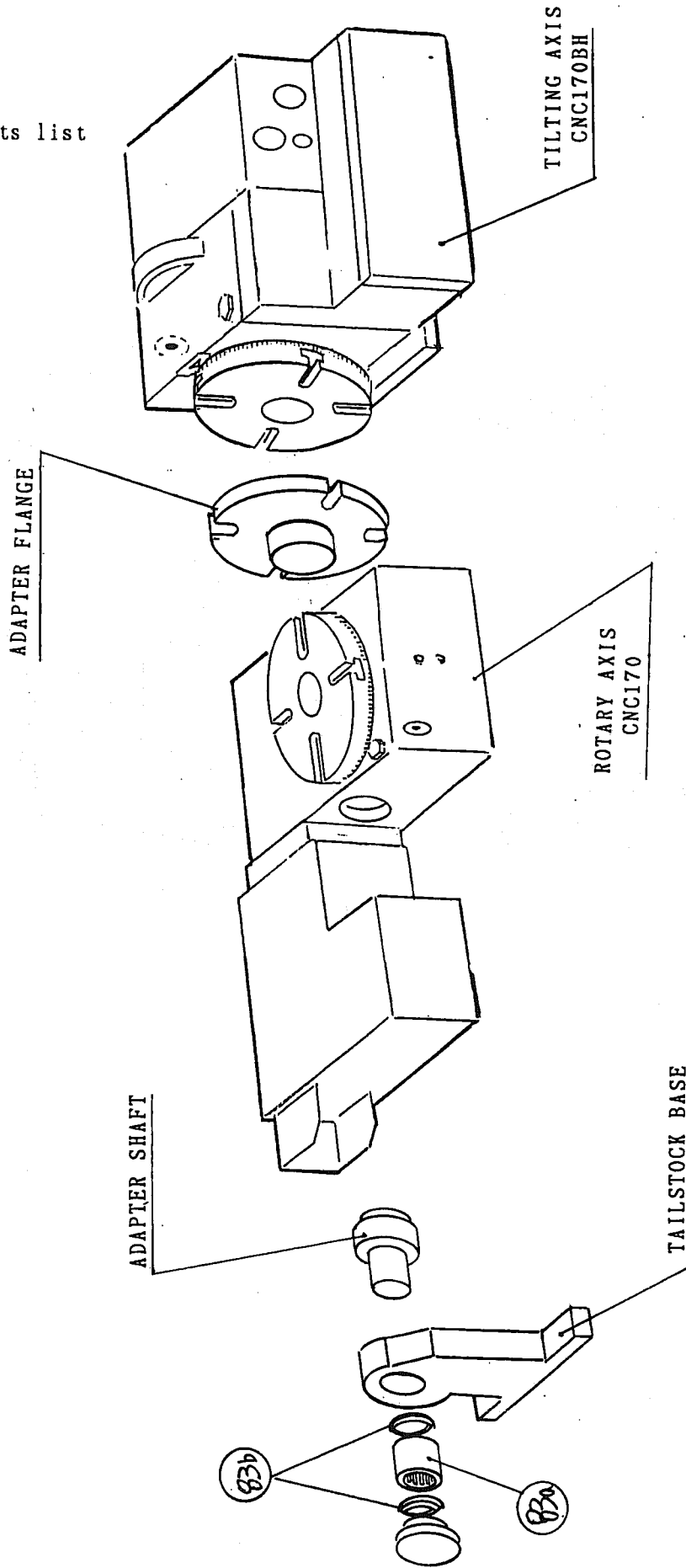

5AX-170 GENERAL  
TCZ-34002

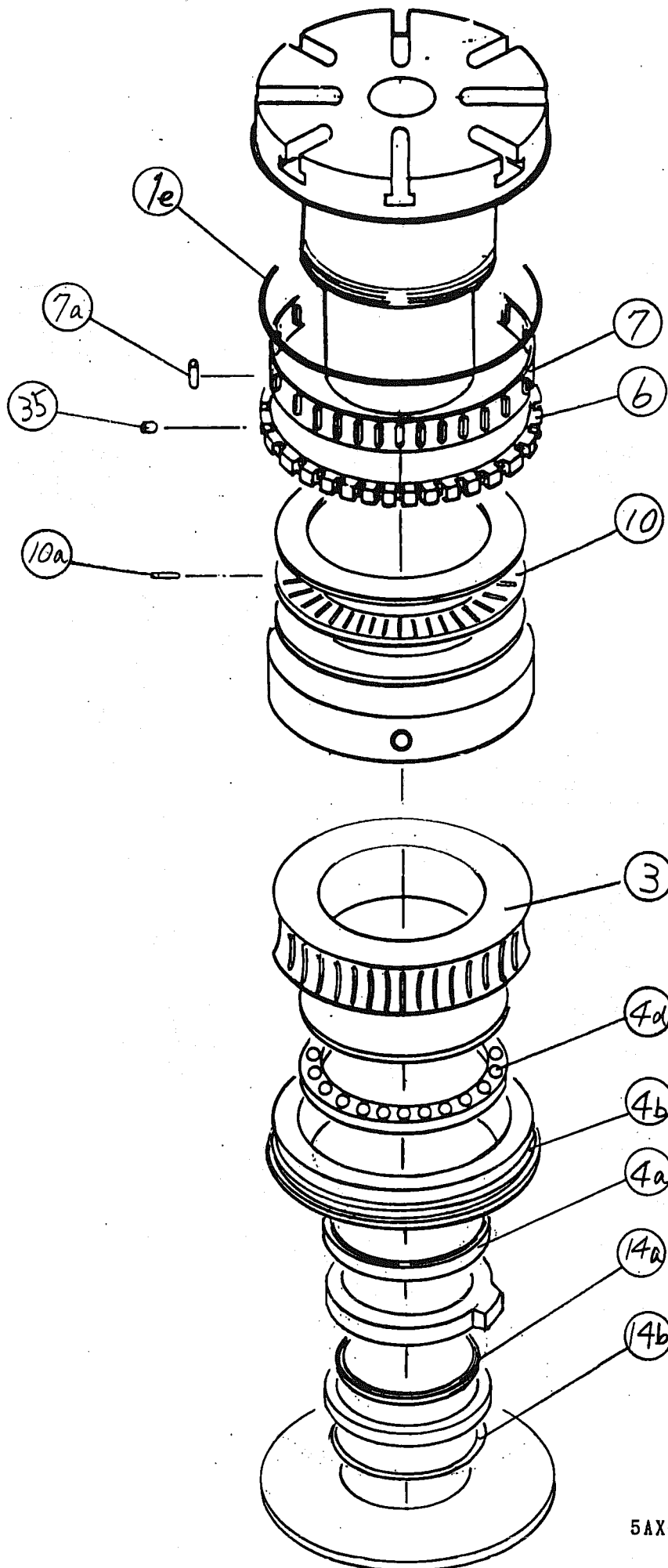

5AX-170 ROTARY AXIS SPINDLE  
TCZ-34003

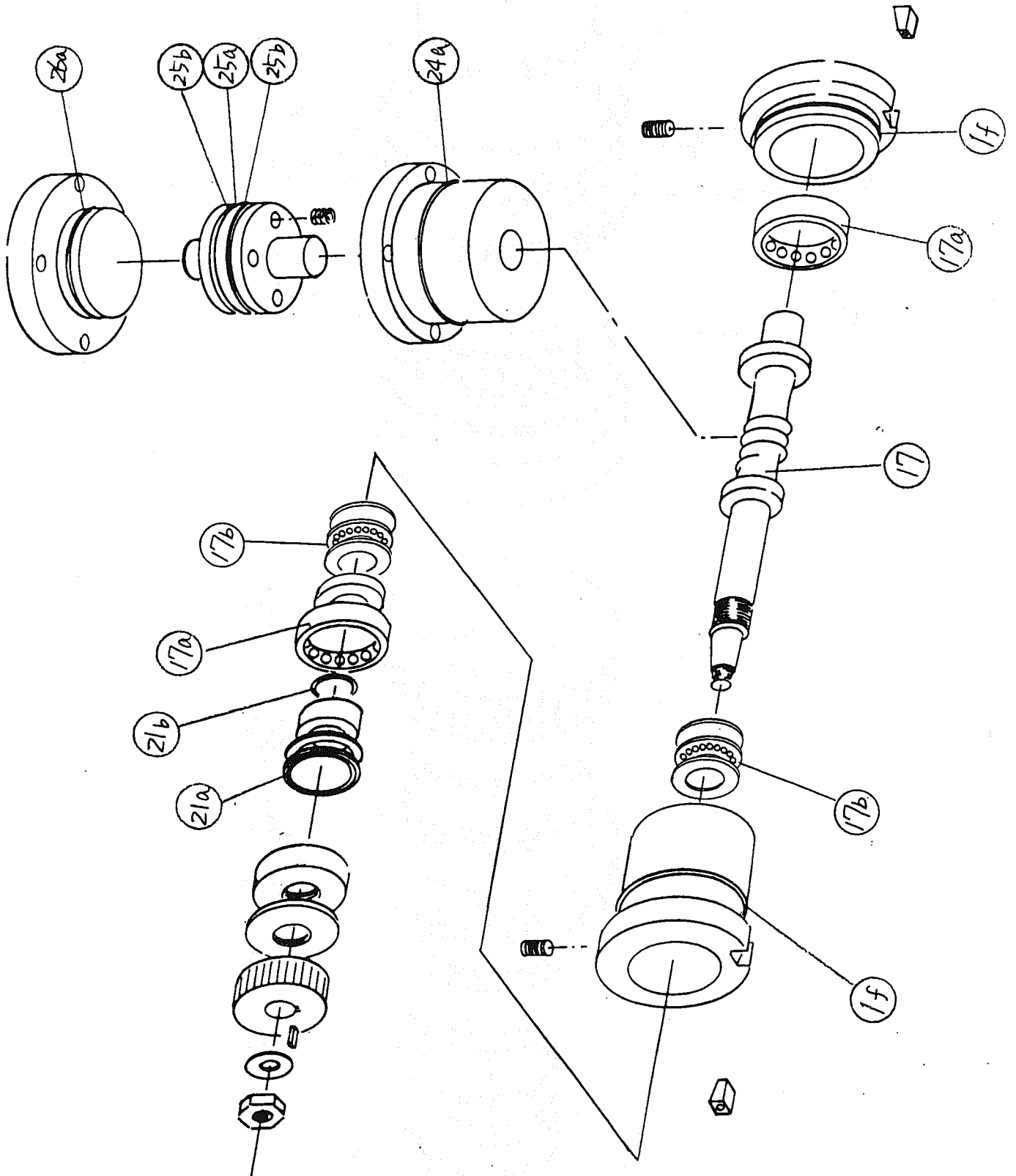

5AX-170 ROTARY AXIS WORM SHAFT  
TCZ-34004

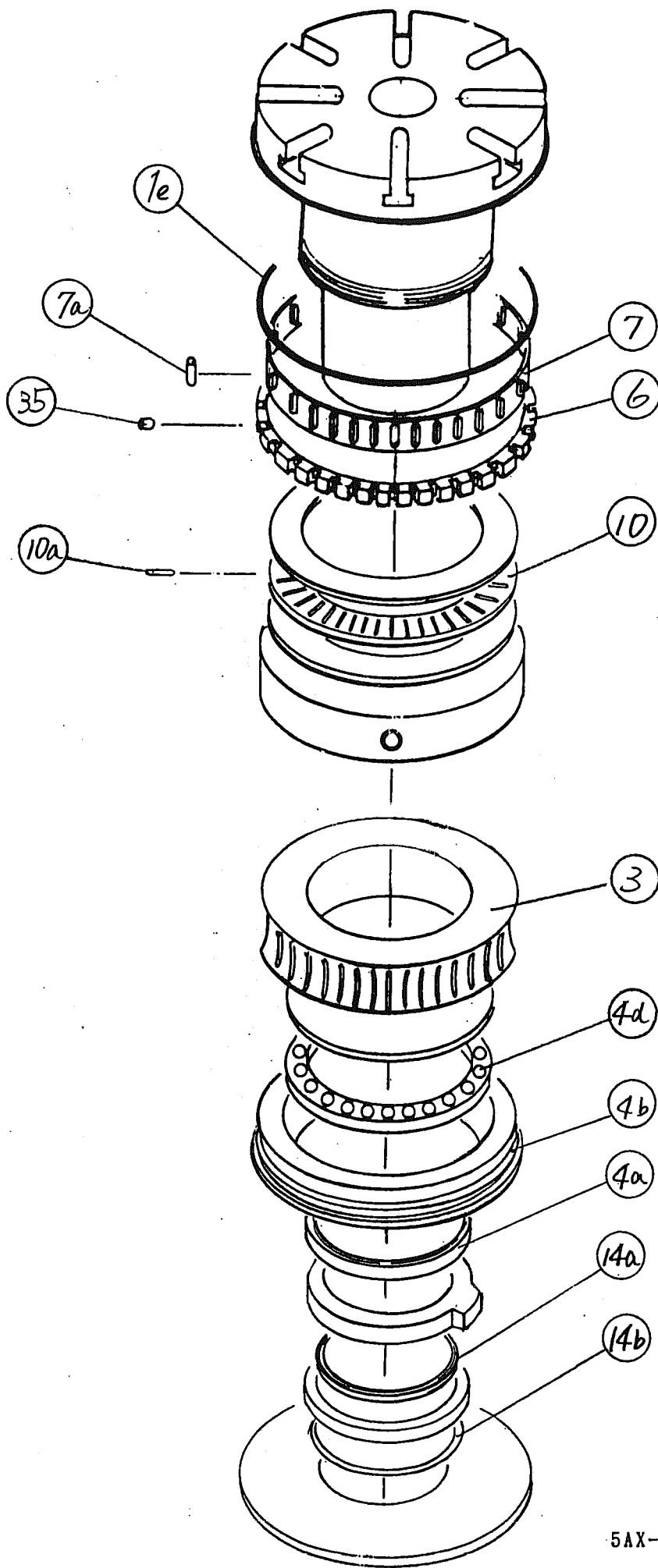

5AX-170 TILTING AXIS SPINDLE  
TCZ-34005

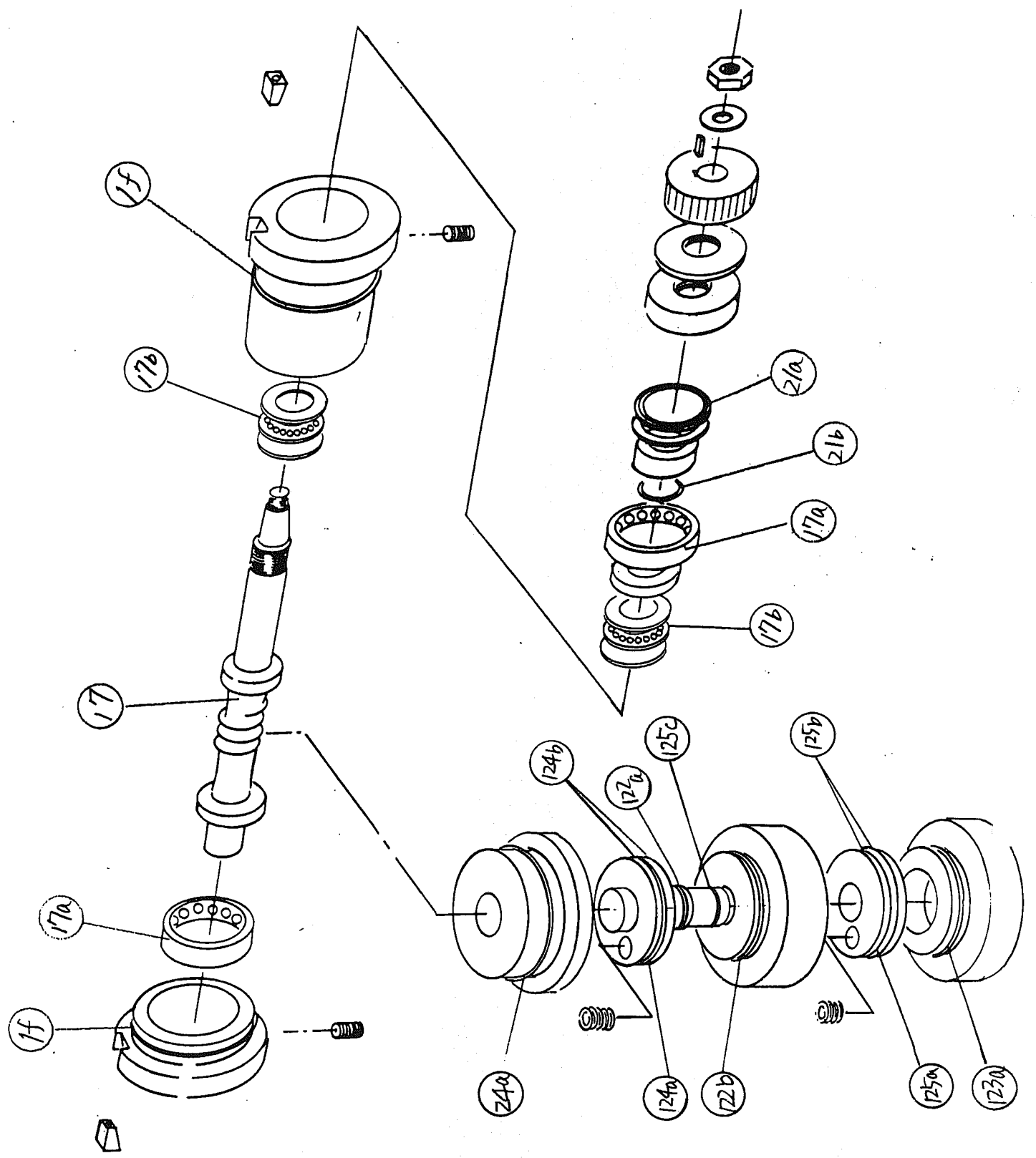

5AX-170 TILTING AXIS WORM SHAFT  
TCZ-34006

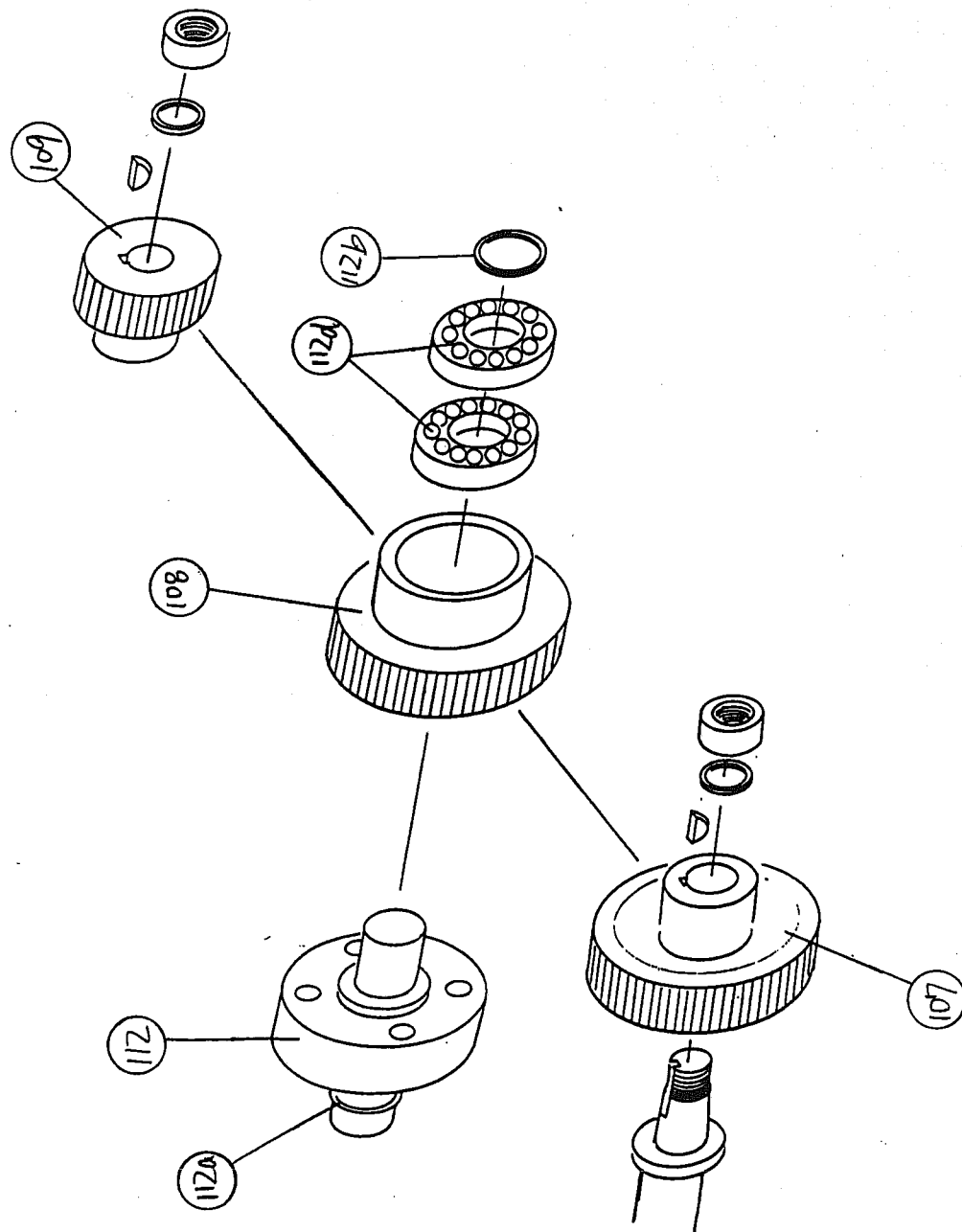

5AX-170 TILTING AXIS GEAR BOX  
 TCZ-34007

No.	REFERENCE	ITEM	PIECES	REMARKS
83a	TCZ-34002	NEEDLE BEARING	1	TAF253320
83	TCZ-34002	SEAL	1	OS 25334
3	TCZ-34003,34005	WORM WHEEL	2	
6	TCZ-34003,34005	RETAINER FOR #35	2	
7	TCZ-34003,34005	RETAINER FOR #7a	2	
10	TCZ-34003,34005	RETAINER FOR #10a	2	
35	TCZ-34003,34005	TUBULASR ROLLER	48	φ 6 * 7L
1e	TCZ-34003,34005	FACE SEAL	2	φ 136
4a	TCZ-34003,34005	SEAL	2	UE60829
4b	TCZ-34003,34005	O-RING	2	G130
4d	TCZ-34003,34005	BEARING	2	16012
7a	TCZ-34003,34005	NEEDLE ROLLER	72	φ 4 * 11L
10a	TCZ-34003,34005	NEEDLE ROLLER	48	φ 2 * 7.5L
14a	TCZ-34003,34005	SEAL	2	OS55674
14b	TCZ-34003,34005	O-RING	2	G-70
17	TCZ-34004,34006	WORM SHAFT	2	
1f	TCZ-34004,34006	O-RING	4	JISW1517 AN6230-#4
17a	TCZ-34004,34006	BEARING	4	#6003
17b	TCZ-34004,34006	THRUST BEARING	4	#51103
21a	TCZ-34004,34006	OIL SEAL	2	OS28354
21b	TCZ-34004,34006	O-RING	2	WP-13
24a	TCZ-34004	O-RING	2	G-60
25a	TCZ-34004	PACKIN	2	HSD-55 #25a AND #25b ARE SET.
25b	TCZ-34004	BACK-UP RING	2	TC-HSD-55
26a	TCZ-34004	O-RING	1	GSO
122a	TCZ-34004	O-RING	1	P-20
122b	TCZ-34004	O-RING	1	G-50
123a	TCZ-34004	O-RING	1	G-50
124a	TCZ-34004	PACKIN	1	HSD-55 #124a AND #124b ARE SET.
124b	TCZ-34004	BACK-UP RING	2	TC-HSD-55
125a	TCZ-34004	PACKIN	1	HSD-55 #125a AND #125b AND SET.
125b	TCZ-34004	BACK-UP RING	2	TC-HSD-55
125c	TCZ-34004	O-RING	1	P-12
107	TCZ-34007	MAIN GEAR	1	
108	TCZ-34007	IDLE GEAR	1	
109	TCZ-34007	MOTOR GEAR	1	
112	TCZ-34007	SHAFT FLANGE FOR IDLE GEAR	1	
112a	TCZ-34007	O-RING	1	P-16
112b	TCZ-34007	SNAP RING	1	ISTW-15
112d	TCZ-34007	BEARING	2	#6902

## APPENDIX

- 1 How to obtain the coordinate of tilting center by measurement
- 2 Relation between work dia. and length for allowable maximum load
- 3 Relation between work dia. and length for allowable work inertia
- 4 Coordinate calculating equation for table center  
in relation to tilting angle
- 5 Rapid traverse positioning time
- 6 Interference zone
- 7 Relation between tilting angle and X & Z Coordinate value
- 8 Composition of 5AX-170WA (Standard spec.)
- 9 Composition of 5AX-170WA  
(Optional spec. for automatic program selection)
- 10 Composition of 5AX-170WA (Optional spec. for AWC system)
- 11 Wiring diagram of junction box for 5AX-170DA and 5AX-170WA

1 How to obtain the coordinate of tilting center by measurement

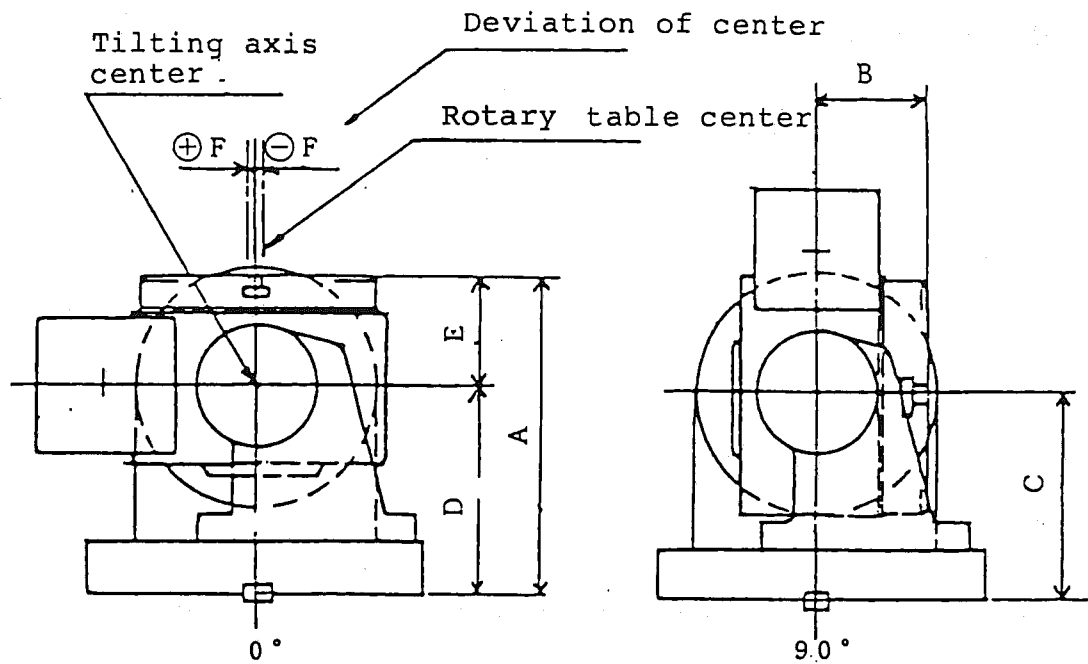

No.	Location	Value	Remark
1	A (    mm )	.	☆ Measure A, B & C; then calculate D, E & F from the following equations.  $D = (A - B + C) / 2$  $E = A - D$  $F = (B + C - A) / 2$
2	B (    mm )	.	
3	C (    mm )	.	
4	D (    mm )	.	
5	E (    mm )	.	
6	F (    mm )	.	

2 Relation between work dia. and length for allowable maximum load

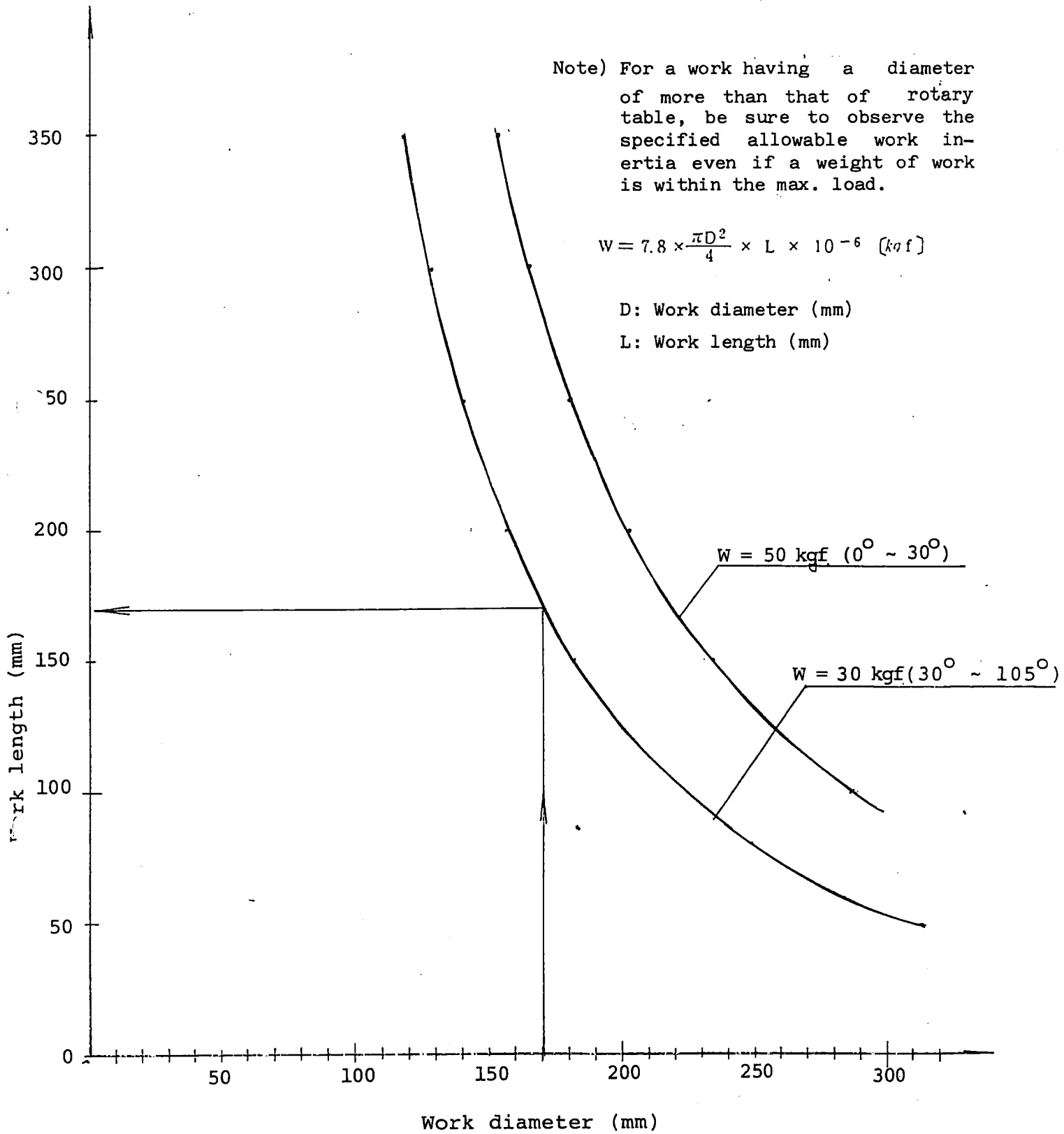

Utilizing method of above figure

A work, having  $\phi 170$  mm dia. and a length of within 170 mm, will have an allowable max. load of 30 kgf.

3 Relation between work dia. and length for allowable work inertia

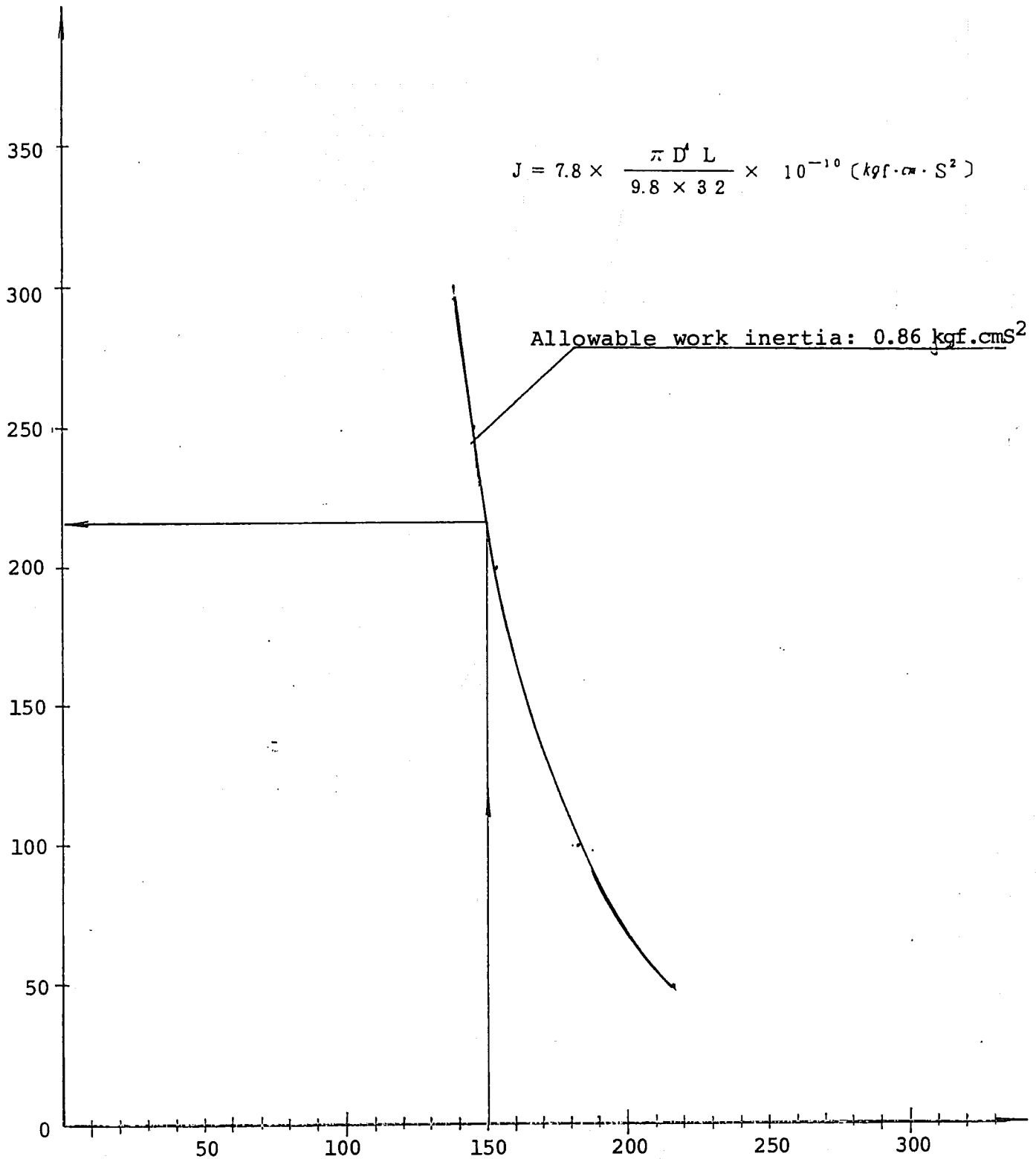

Utilizing method of above figure

A work, having  $\phi 150$  mm dia. and a length of within 216 mm, will have an allowable work inertia of within  $0.86 \text{ kgf}\cdot\text{cm}\cdot\text{S}^2$ .

4 Coordinate calculating equation for table center  
in relation to tilting angle

Assuming that the coordinates of table center when the tilting axis angle =  $0^\circ$  (horizontal) are  $Y = 0$  and  $Z = 0$  respectively, the coordinates when the tilting angle is  $\theta^\circ$  can be calculated by the following equations.

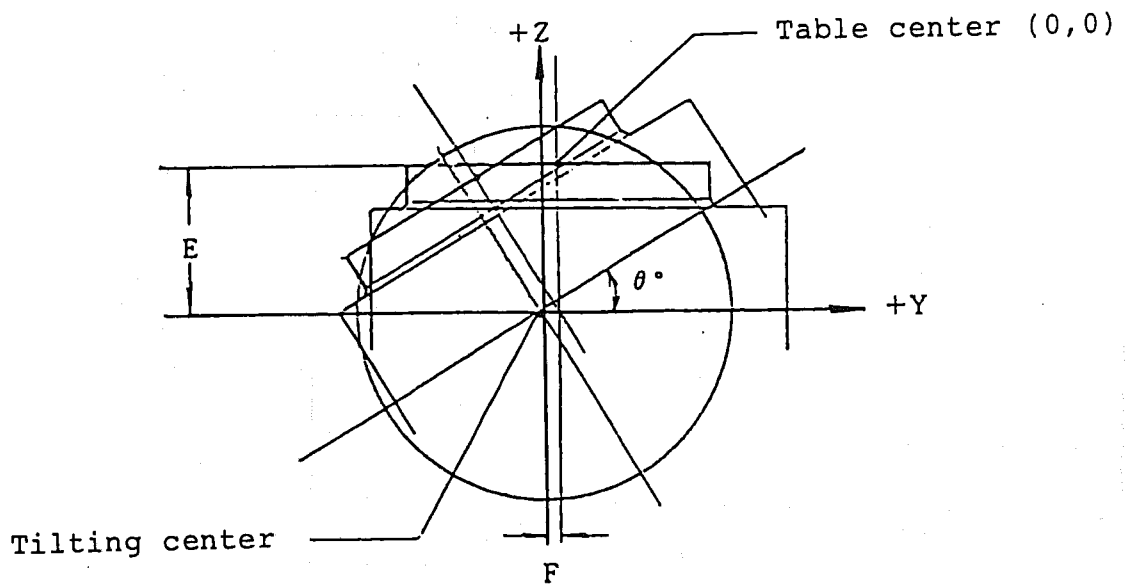

For values of E and F, use those values described at the time of shipping.

$$Y = F\cos\theta - E\sin\theta - F$$

$$Z = E\cos\theta + F\sin\theta - E$$

When  $E = 50$  and  $F = 0$ , these values become as follows:

$$Y = -50\sin\theta$$

$$Z = 50\cos\theta - 50$$

Relation between  $\theta$  and  $Y$  &  $Z$  coordinates is shown in the table of next page.

Tilting angle $\theta$	Table center	
	Y	Z
$0^\circ$	0	0
$5^\circ$	- 4.358	- 0.190
$10^\circ$	- 8.682	- 0.760
$15^\circ$	- 12.941	- 1.704
$20^\circ$	- 17.101	- 3.015
$25^\circ$	- 21.131	- 4.685
$30^\circ$	- 25.	- 6.699
$35^\circ$	- 28.679	- 9.042
$40^\circ$	- 32.139	- 11.698
$45^\circ$	- 35.355	- 14.645
$50^\circ$	- 38.302	- 17.861
$55^\circ$	- 40.958	- 21.321
$60^\circ$	- 43.301	- 25.
$65^\circ$	- 45.315	- 28.869
$70^\circ$	- 46.985	- 32.899
$75^\circ$	- 48.296	- 37.059
$80^\circ$	- 49.240	- 41.318
$85^\circ$	- 49.810	- 45.642
$90^\circ$	- 50.	- 50.
$95^\circ$	- 49.810	- 54.357
$100^\circ$	- 48.296	- 58.682
$105^\circ$	- 46.985	- 62.941

The following times are set as standard setting when driven by  $\alpha$  (alpha) controller. Therefore, when it is desirable to shorten the moving time, please consult us in advance.

(1) Moving pre-processing time (parallel with unclamping operation):

- 500 msec (PRM#59)
- 650 msec (PRM#11)

(2) Final positioning time:

Moving angle  
( $^{\circ}$ )

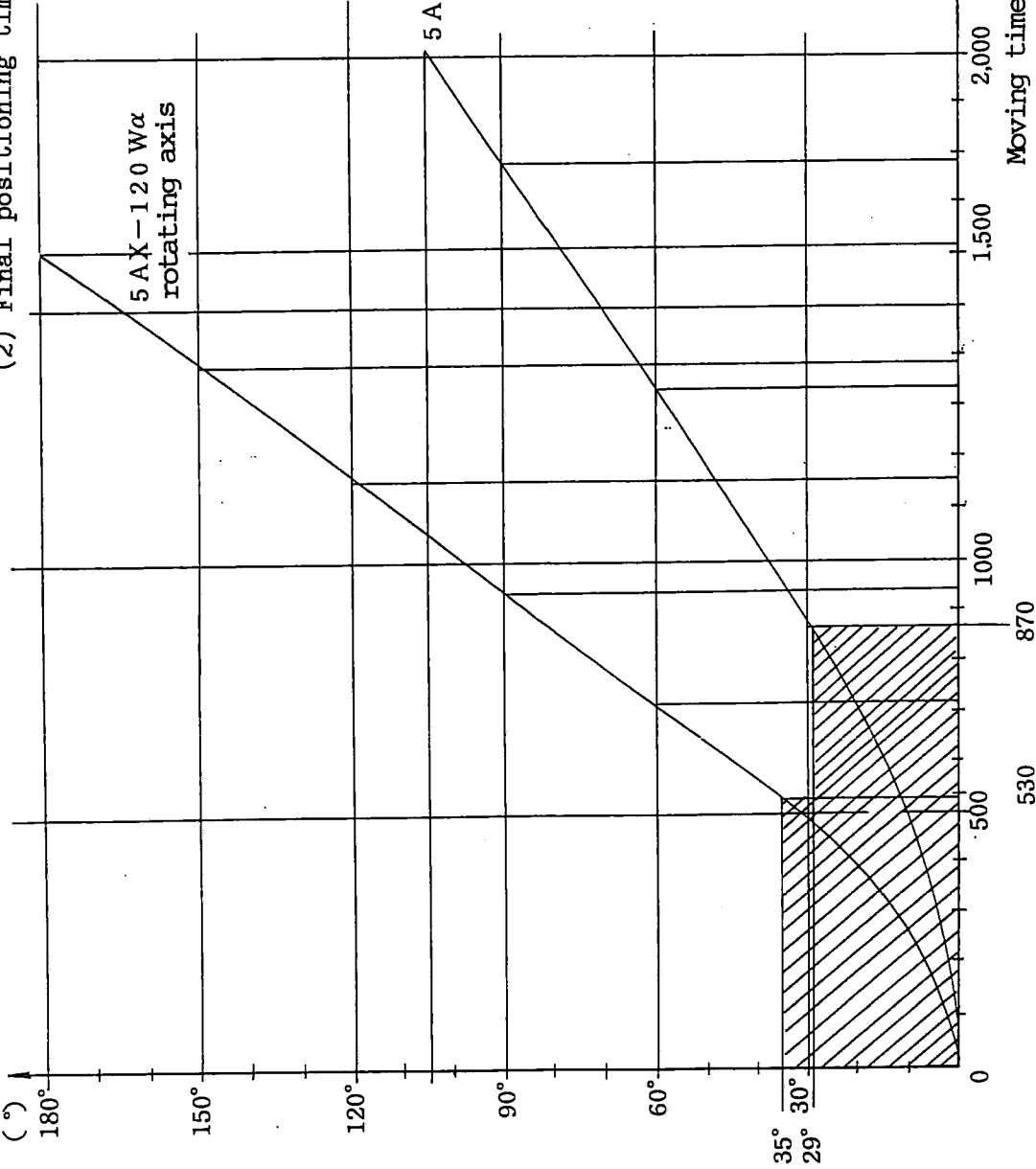

5 AX-120 W $\alpha$  tilting axis

Item	Axis	Rotating axis	Tilting axis
Servo loop gain		30 sec <sup>-1</sup>	
Acc./decel. time const.		Ex. function 58 msec	Ex. function 100 msec
Rapid traverse rate		22.2 RPM	11.1 RPM

Item	Axis	Rotating axis	Tilting axis
Unclamp time		150 msec	200 msec
Clamp time		100 msec	150 msec

Error:  $\pm 20\%$

Clamp action is executed in parallel with 1-block signal finish operation.

In areas , the table moves only in acceleration and deceleration modes and not in rapid traverse mode.

6 Interference zone

The followings are reference data for the standard NIKKEN 5AX-170.  
In case of special spec., please consult us in advance.

Tilting angle range 0° (horizontal) to 45°

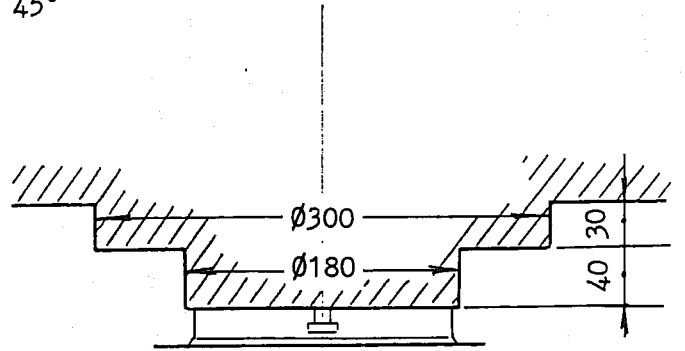
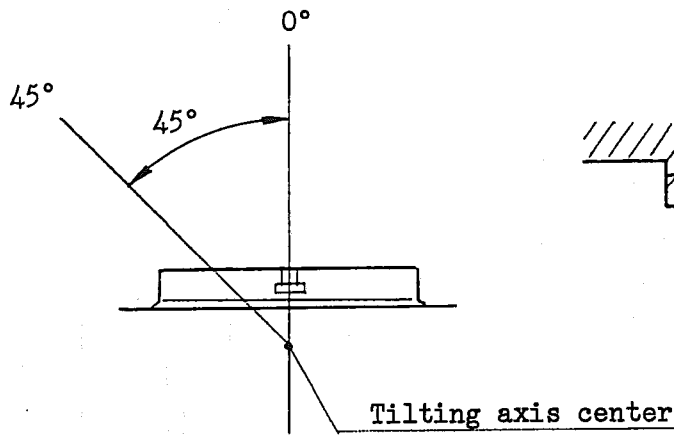

Tilting angle range 45° to 90° (vertical)

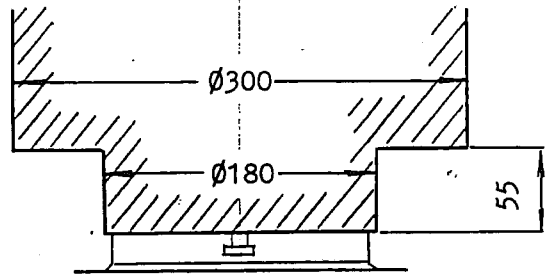
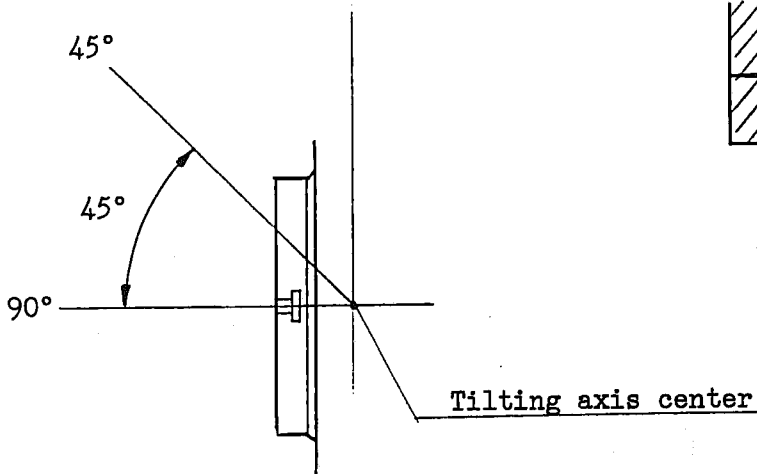

Tilting angle range 90° (vertical) to 105°

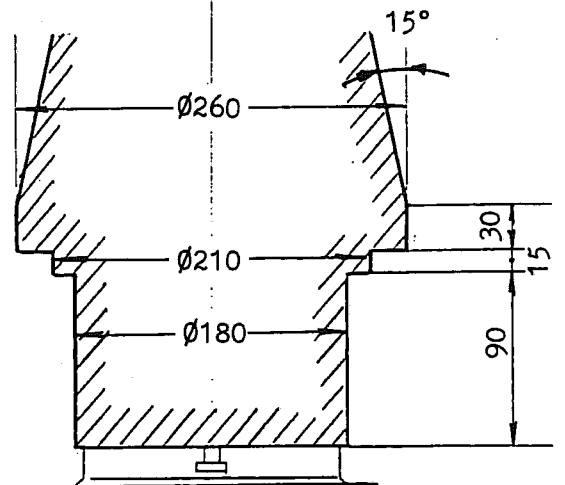
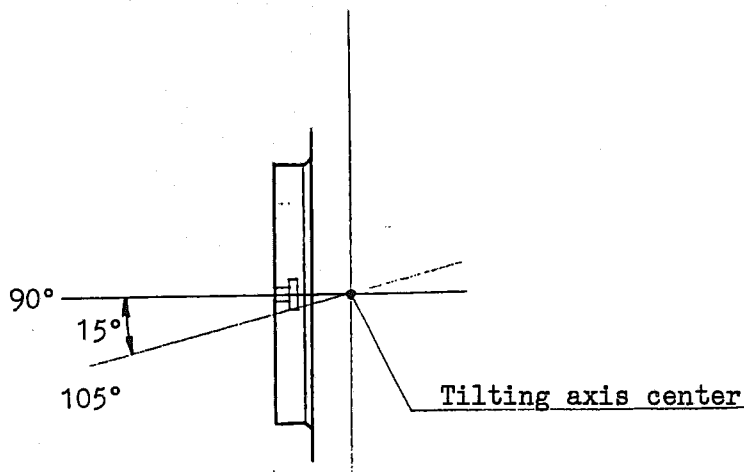

7 Relation between tilting angle and X & Z Coordinate value

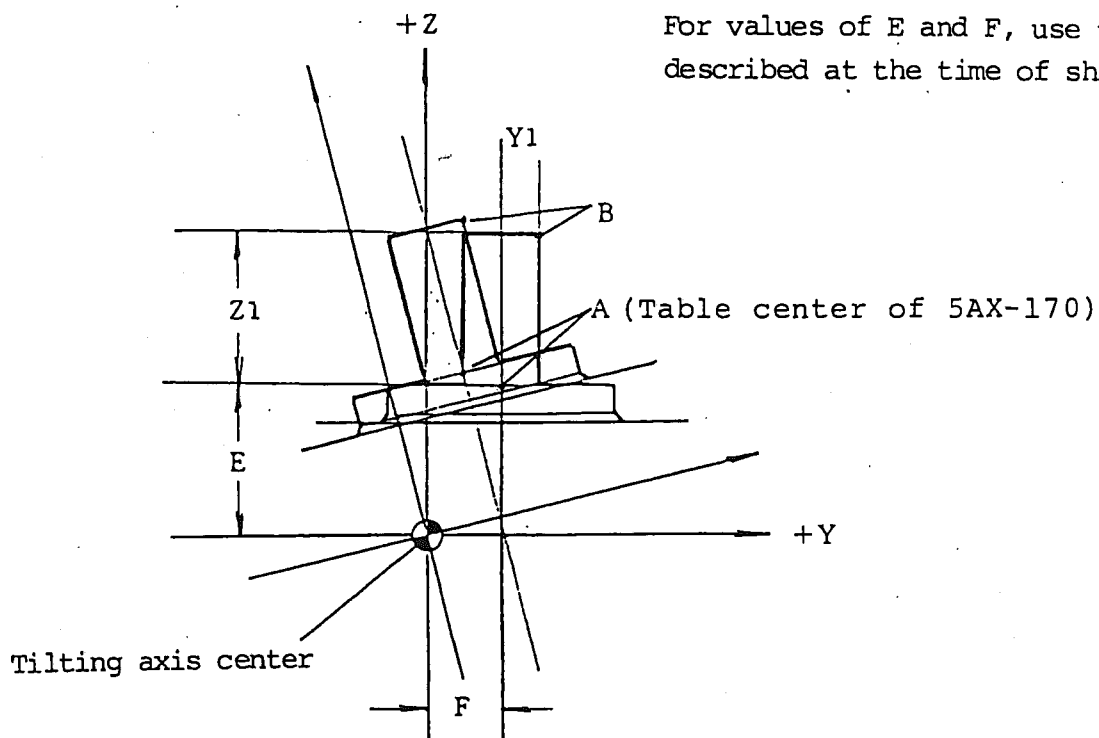

For values of E and F, use those values described at the time of shipping.

Assuming that the tilting center is at coordinate values (0, 0), coordinate values of respective points become as follows:

A-point for tilting angle of zero degree

$$Y(A0) = F$$

$$Z(A0) = E$$

A-point for tilting angle of  $\theta$  degrees

$$Y(A\theta) = F\cos\theta - E\sin\theta$$

$$Z(A\theta) = E\cos\theta + F\sin\theta$$

B-point for tilting angle of zero degree

$$Y(B0) = F + Y1$$

$$Z(B0) = E + Z1$$

B-point for tilting angle of  $\theta$  degree

$$Y(B\theta) = (F + Y1)\cos\theta - (E + Z1)\sin\theta$$

$$Z(B\theta) = (E + Z1)\cos\theta + (F + Y1)\sin\theta$$

8 Composition of 5AX-170WA (Standard spec.)

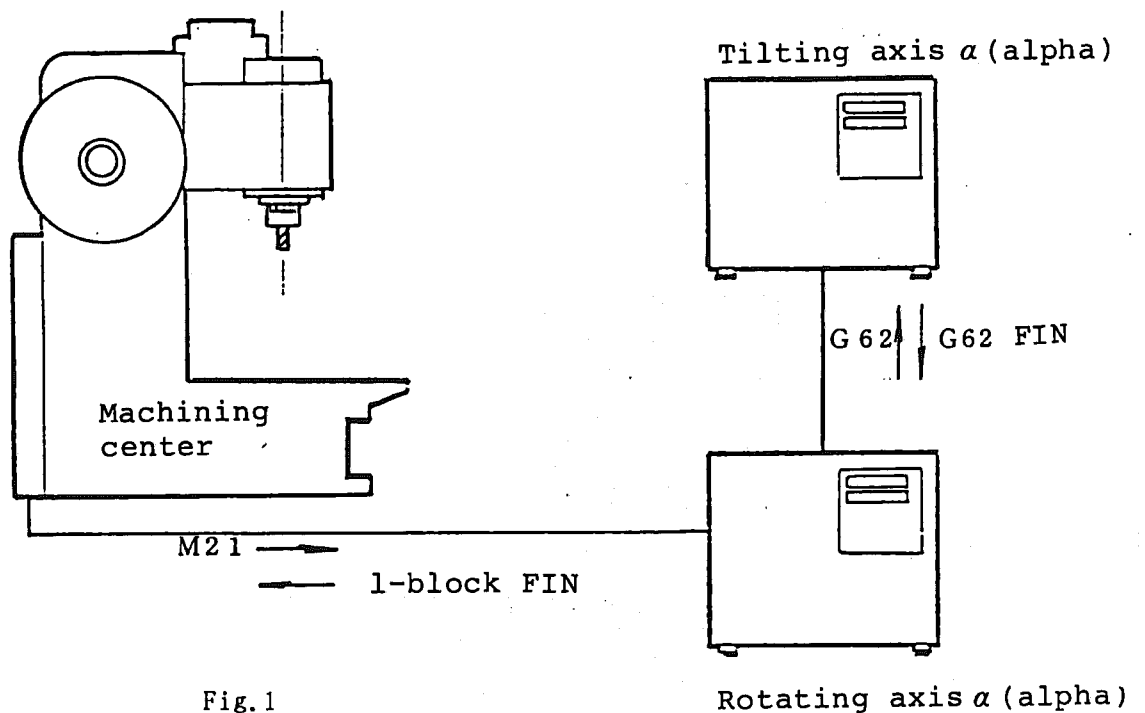

Fig.1

The emergency stop signal to the rotating axis  $\alpha$  (alpha) can be entered only through B-contact.

M21: Any number will do for M-signal of M/C, but should be valid only for the relevant block under the DISTRIBUTION END mode.

1-block FIN: Finish signal for M21

G62: G62 signal for the rotating axis  $\alpha$  (alpha) causes the tilting axis  $\alpha$  to start. When the rotating axis movement instruction and G62 instruction are given in the same block, the both axes move almost simultaneously.

Viewing from the tilting axis  $\alpha$  (alpha) side, G62 signal should be considered as the same with M21 signal (start signal).

G62 FIN: Viewing from the tilting axis  $\alpha$  (alpha) side, G62 FIN signal should be considered as the same with 1-block FIN signal.

Cable layout and junction box for 5AX-170W (alpha)

Installation of the junction box and connection of cables are as illustrated in Fig. 2.

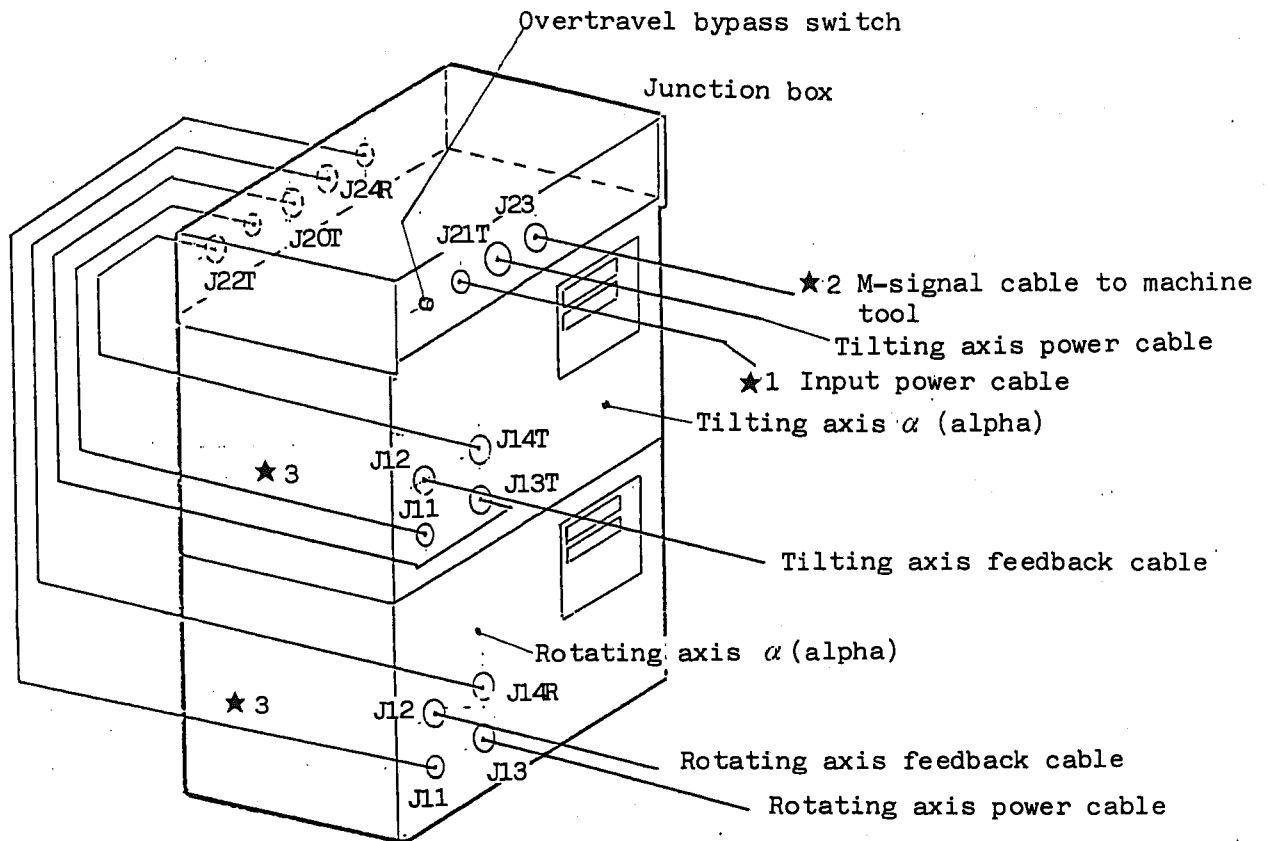

Fig. 2

★1 The input power (single-phase, AC200 ~ 220V) should be connected to this connection.

Incidentally, in the event when the input power voltage is AC240V, be sure to contact us in advance.

(Voltage adjustment of power supply in the junction box becomes necessary.)

★2 Emergency stop signal from the machine tool can be entered only through B-contact.

★3 Power is supplied from the junction box to each  $\alpha$  (alpha) controller, so that connection of each cable should be carried out correctly.

Cable layout and junction box

$\alpha$  for tilting axis (Da type junction box)

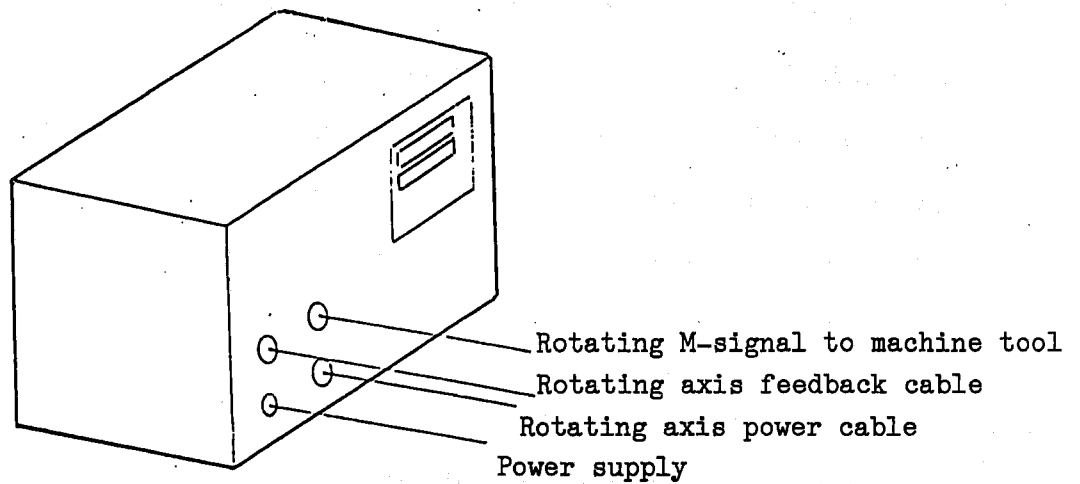
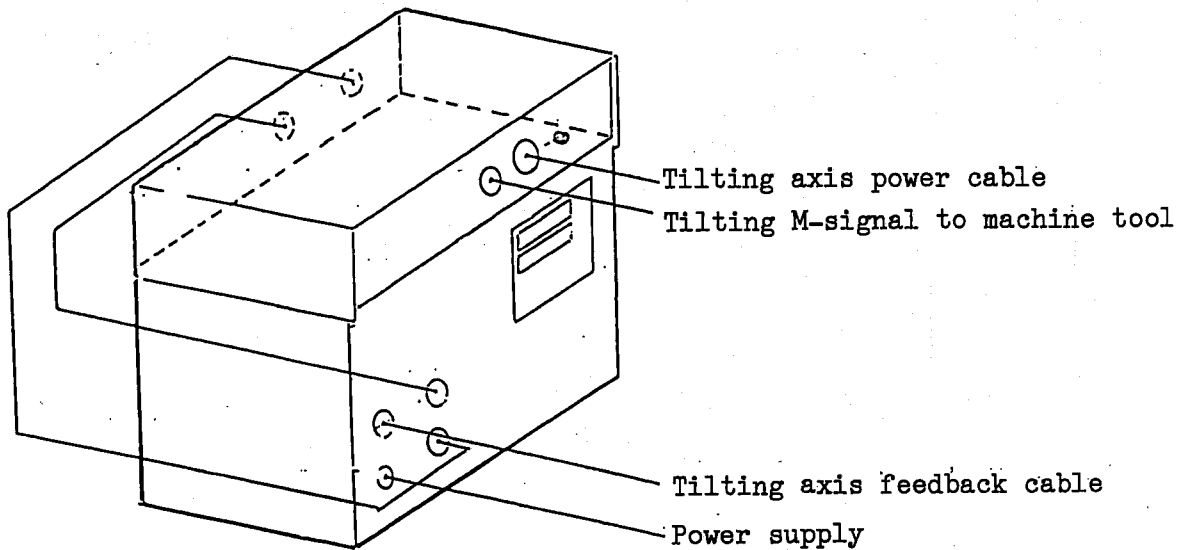

Fig.4  $\alpha$  for rotating axis (standard  $\alpha$ )

In both cases, the emergency stop signal is given to b-contact.

9 Composition of 5AX-170WA  
(Optional spec. for automatic program selection)

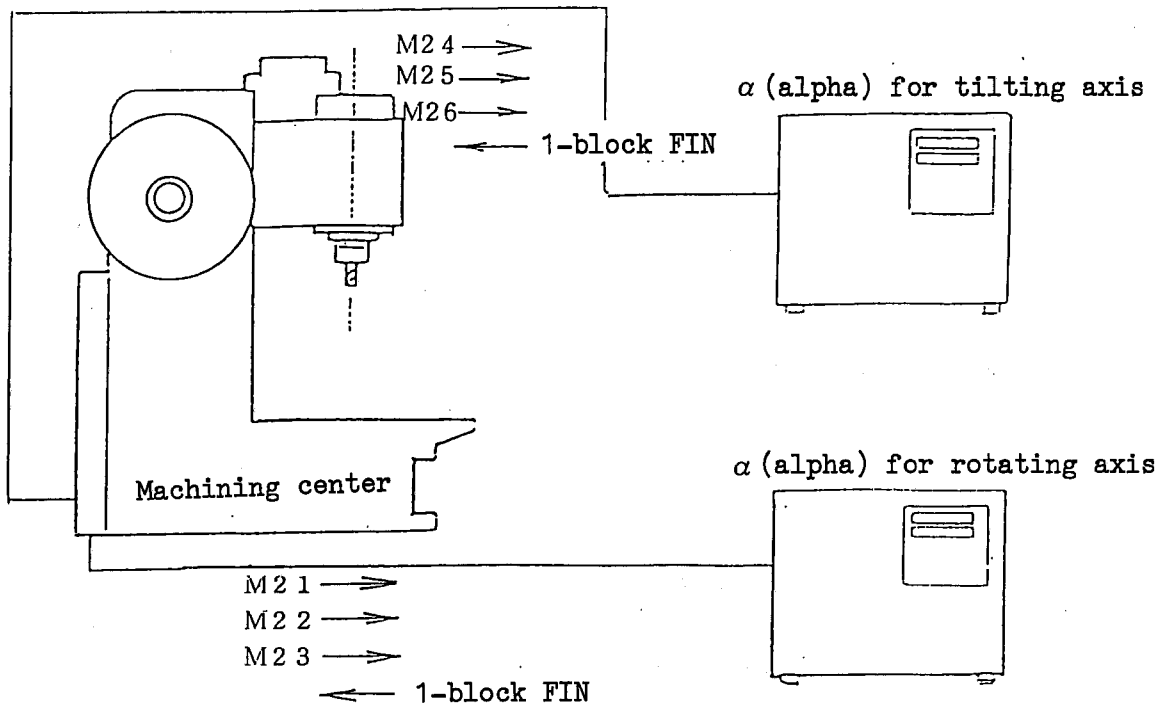

Fig. 3

Both emergency stop signal for rotating axis  $\alpha$  and tilting axis  $\alpha$  are given to b-contact.

M21: Rotating axis; Program start

M22: Rotating axis; Reset to machine zero-point and N000

M23: Rotating axis; Jump to program execution address

M24; Tilting axis; Program start

M25: Tilting axis; Reset to machine zero-point and N000

M26: Tilting axis; Jump to program execution address

Functions M21 to M23 are completed when 1-block finish signal is given in case of rotating axis, and functions M24 to M26 are completed when 1-block finish signal is given in case of rotating axis.

Concerning the handling of each signal, reference should be made to Chapter 6.7 List of function corresponding to automation in  $\alpha$  Instruction Manual.

10 Composition of 5AX-170WA (Optional spec. for AWC system)

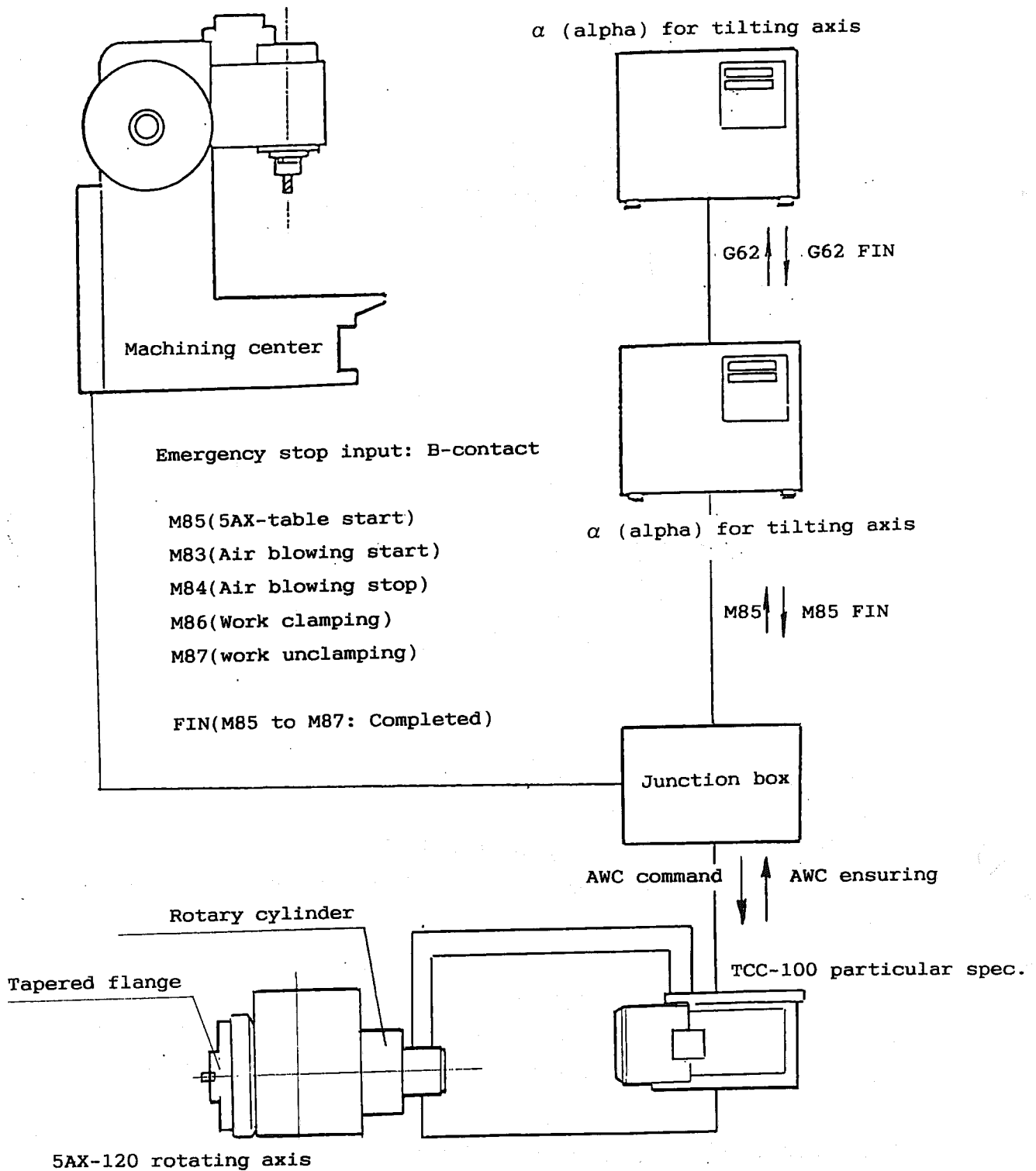

M83 & M84 are not required to be confirmed.  
Time charts for M83, M84, M86 and M87 will be determined by separate agreement.

Solenoid valve for work unclamping, solenoid valve (pneumatic) for air blowing and pressure switches for ensuring work clamp/unclamp are incorporated.

APPENDIX

11 Wiring diagram of junction box for 5AX-120D $\alpha$  (alpha) and 5AX-120W $\alpha$  (alpha) 5AX-170 D $\alpha$

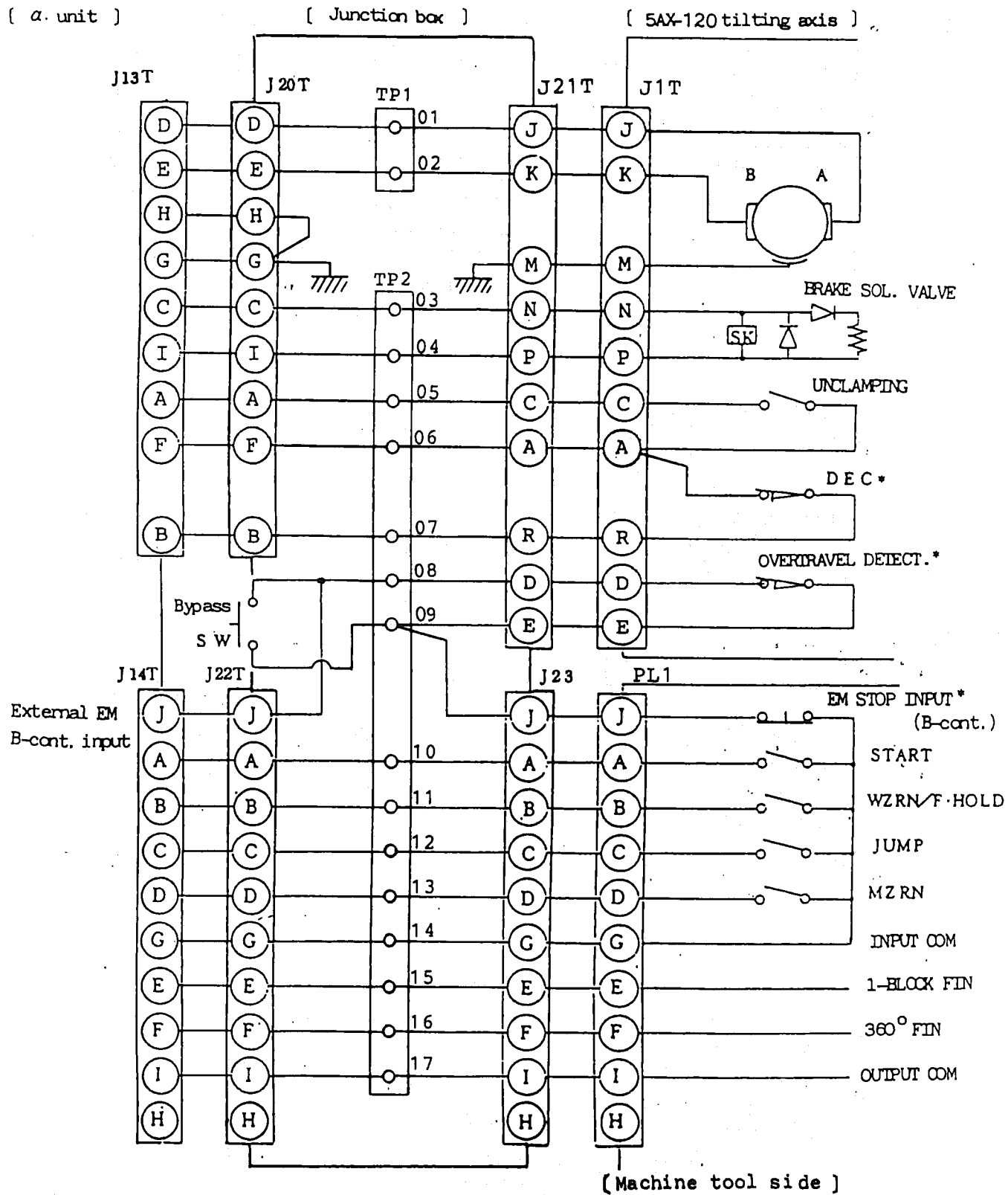

5AX-120 D $\alpha$  (alpha)  
5AX-170 D $\alpha$

Emergency stop signal can be entered only through B-contact.

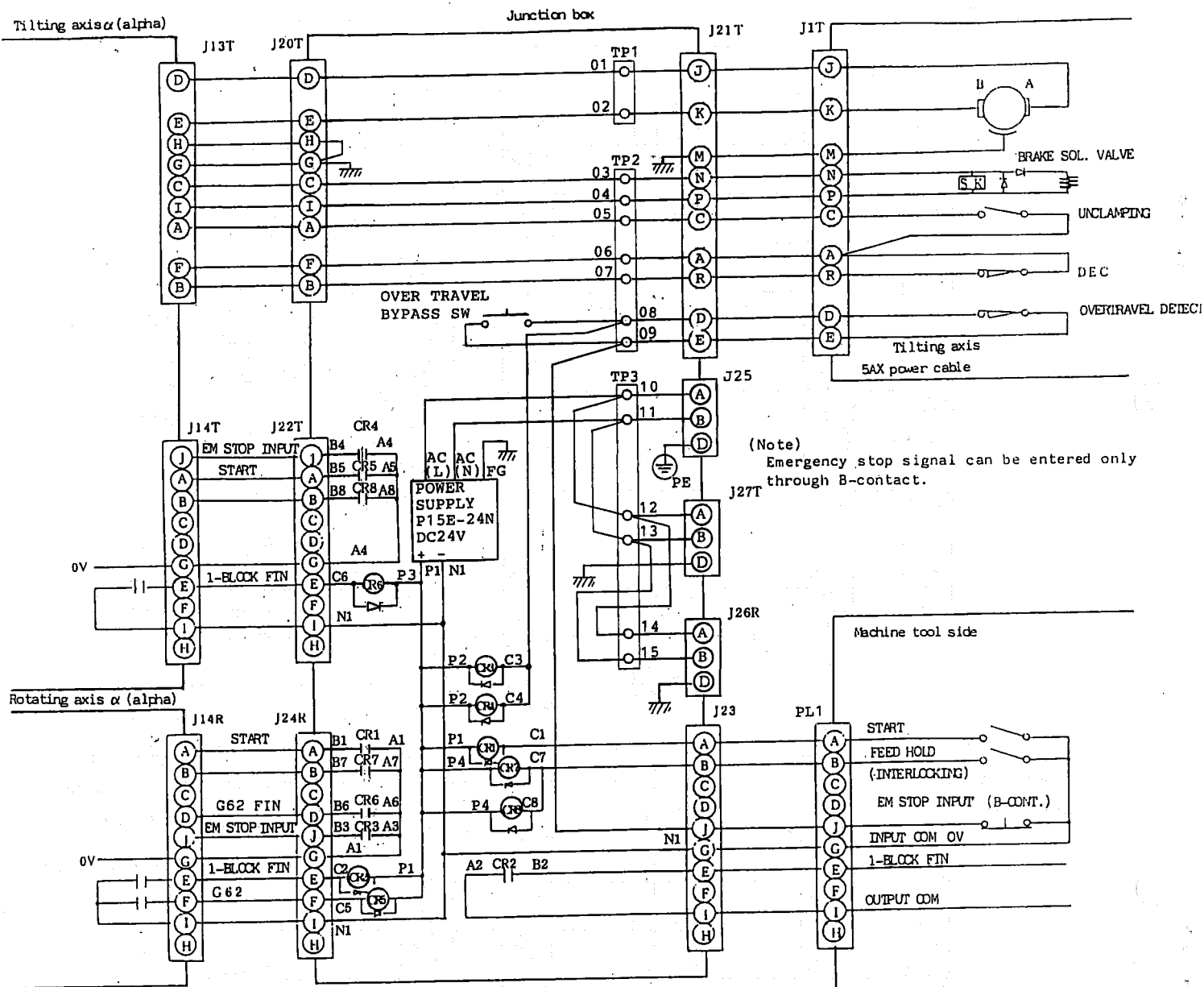

(Note)  
Emergency stop signal can be entered only through B-contact.

5AX-120W α  
5AX-170W α

Symbol	Receptacle	Straight Plug
PL1	MS3102A18-1P	MS3106B18-1S
J1T	JL04V-2E28-11PEZ	JL04V-6A28-11SEZ
J13T	JL04V-2E24-11SE	JL04V-6A24-11PE
J14R	MS3102A18-1S	MS3106B18-1P
J14T	MS3102A18-1S	MS3106B18-1P
J20T	JL04V-2E24-11PE	JL04V-6A24-11SE
J21T	JL04V-2A28-11SEZ	JL04V-6A28-11PEZ
J22T	MS3102A18-1P	MS3106B18-1S
J23	MS3102A18-1S	MS3106B18-1P
J24R	MS3102A18-1P	MS3106B18-1S
J25	JL04V-2E18-10PE	JL04V-6A18-10SE
J26R	JL04V-2E18-10SE	JL04V-6A18-10PE
J27T	JL04V-2E18-10SE	JL04V-6A18-10PE

Terminal  
MIBU TP1 MTB-20  
TP2-TP3 MTB-15S

Power Supply  
COSEL P15E-24N  
DC24V 0.75A

Relay Unit (CR1 - CR8)  
YASKAWA R1U-08E/G24