

**NIKKEN**

**CNC AUTO. TABLE**

with **NIKKEN-9000 DC**

Instruction Manual

The controller of this circular table is based on





**FANUC Mate P-MODEL E**



**NIKKEN KOSAKUSHO WORKS, LTD.**

Manufacturer:  
9-2, 5-chome, Higashi Ishikiri-cho, Higashiosaka, Japan.  
Telephone: 0729-81-5861 (KEY) Telex: 5353 390 NIKKEN J

C O N T E N T S

	Page
1. Unpacking and transfer .....	1
2. Oiling .....	1
3. Power source and voltage .....	2
4. Air supply .....	2
5. List of G code .....	3
6. List of M code .....	6
7. Description of F, A, O, N, D, and P .....	7
8. Explanation of control board .....	10
8-1 Power .....	10
8-2 Power ON .....	11
8-3 Power OFF .....	11
8-4 Emergency stop .....	11
8-5 Operator's panel button .....	11
8-5-1 Mode selection .....	12
8-5-2 Rapid feed over-ride .....	13
8-5-3 Jog feed .....	14
8-5-4 Operator's panel .....	14
8-5-5 Alarm indication .....	15
9. Programming method .....	16
9-1 Power ON .....	16
9-2 Operation of CURSOR   keys .....	16
9-3 Operation of   keys .....	16
9-4 Operation of program key .....	16
9-5 Registration of program No. and sequence No. .....	17

	Page
9-6 Programming by menu system .....	18
9-6-1 Calling and confirming G code .....	18
9-6-2 Example of programming .....	18
10. Manual confirmation of function (MDI).....	23
10-1 Zero-point return .....	23
10-2 Confirmation of function by operating circular table .....	24
11. Practical application of program .....	24
12. Registration into memory, search, and deletion of program .....	29
12-1 Registration of program .....	29
12-2 Search and confirmation of program No. ....	29
12-3 Deletion and erase of program .....	30
13. Description of keys Insert, Alter, and Delete.	30
13-1 Insertion of word .....	30
13-2 Alteration of word .....	31
13-3 Deletion of word .....	32

## 1. Unpacking and transfer

Pay attention to the autotable in transferring after unpacking it.

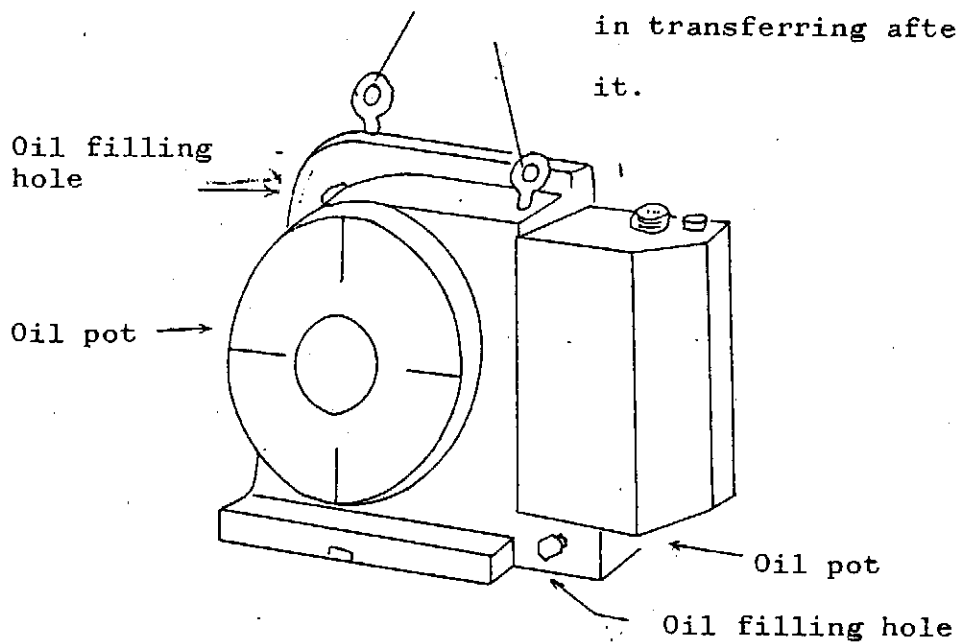

## 2. Oiling

Gear oil is incorporated in the totally enclosed type reservoir, so that there is little possibility of mingling-in of cutting oil and leakage of lubricating oil. Be cautions that there provided two oil filling holes in this table! Be sure to check oil level through the oil pots every day, and supply oil properly if insufficient.

Recommended oil: Super Multi-oil #68

### 3. Power source and voltage

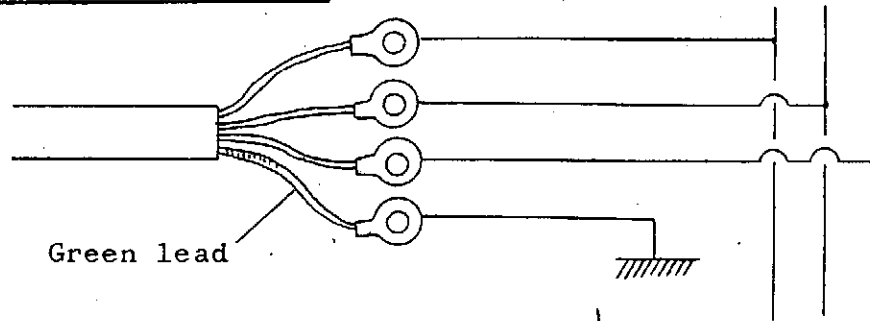

Connect the green lead wire to the ground and the other three wires to the power source: 200 - 220 V, 50/60 Hz, 3  $\phi$ . Consumed power is 2.0 KVA. Connect the green lead wire to the earthing ground in accordance with the second class grounding work or higher.

### 4. Air supply

Supply the table with air of 4 - 6 Kg/cm<sup>2</sup> pressure.

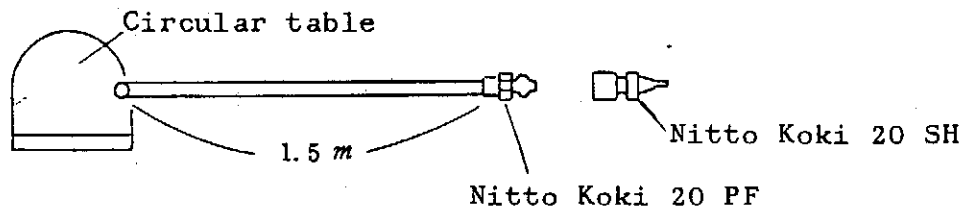

The circular table would not operate if air is not supplied. Lubrication-free type cylinders are incorporated in the table, however, attention should be paid that pure air is to be supplied thereto.

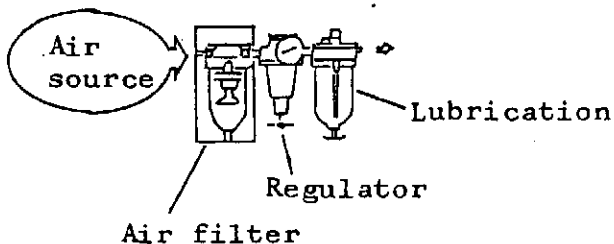

It is recommended to use the air unit shown in the left figure comprising three components: for example, SMC AU311 (PT 1/8 made of sintered metal)

5. List of G code

\* : Modal G Code

	Meaning	Example
G00*	Rapid feed positioning	G00 A30. ;
G01*	Cutting feed  This instruction provides 30 deg. feed at a speed of 1.00 deg./min.	G01 A30. F100. ;
G04	Dwell  This instruction provides t msec dwell.  P1000 proceeds to the next block after 1 sec. waiting.	G04 P.t ;
G08*	Buffer start  When G08 is instructed to the program, blocks are executed one after another without being stopped until G09 instruction is given.	G08 A__ F__ ;  ↓ G09 A__ F__ ;
G09*	Buffer cancel  Cancelling is executed by G09 instruction because G08 instruction is the modal type.	

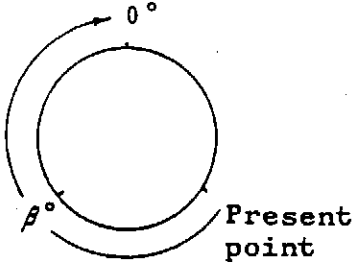

	Meaning	Example
G28	<p>Zero-point return</p> <p>For both the incremental and the absolute cases, the table once passes <math>\beta^\circ</math> and returns to zero point.</p>	<p>G28 A <math>\beta^\circ</math></p> 
G90	<p>Absolute instruction</p>	Used for absolute instruction
G91	<p>Incremental instruction</p>	Used for incremental instruction
G92	<p>Coordinate system setting</p> <p>It is necessary to give instruction of location of the present value to the first block of the absolute instruction.</p>	<p>G92 A <math>\beta</math> ;</p> <p>When the block is read, the entire coordinate system is set with the read position determined as 0 degree.</p>

Desired number of G instructions may be inputted in one block:

Example; G00 G91 G21 \_\_\_\_\_; permissible

However, inconsistent G instructions can not be inputted:

Example; G90 G91 \_\_\_\_\_; impermissible

6. List of M Code

M code	Meaning
M02	<p>End of program</p> <p>When connected with P/C (Single Purpose Machine) M02 should be specified in the end of main program.</p> <p>When connected with N/C, M02 does not need to specify. M99 should be specified in the end of main program instead of M02.</p>
M42	<p>Simultaneous start.</p> <p>refer page 44 on mate P-E operator's Manual</p>
M43	<p>Continuous start.</p> <p>refer page 44 on Mate P-E operator's Manual</p>
M98	<p>Repeatedly calling function.</p> <p>M98 P000 C000 ;</p> <p style="margin-left: 100px;"> </p>
M99	<p>1 End of main program.</p> <p>When connected with N/C, M99 should be specified in the end of main program.</p> <p>2 End of sub-program.</p> <p>M99 should be specified in the end of sub-program.</p>

The instruction M02, M99 or M98 P\_\_\_ may be specified in the same block with the moving instruction.

(Example) A1000 M98 P12 ;

In this case, the sub-program of sub-program NO.12 is called after moving of A axis has been completed.



A	<p>This is the address of angle, and can be indicated as A <math>\overset{\dagger}{9999}^{\circ},999</math>.</p> <p>In order to rotate the table by 30 deg., push keys as follows:</p> <p>A 30.</p> <p style="margin-left: 40px;">↑ When this comma key is pushed, 000 may be omitted.</p>

0	<p>This is the program number.</p> <p>Several programs can be registered in the memory of 9000DC. In order to make a distinction between these programs and other ones, program number 0 should be added.</p> <p style="text-align: right;">01 - 09999</p>
N	<p>This is the sequence number.</p> <p>The program is composed of a group of address N. When the program is executed, the sequence number automatically increases by +1 such as 1→2→3 ....</p> <p style="text-align: right;">N1 - N9999</p>

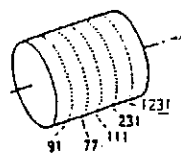
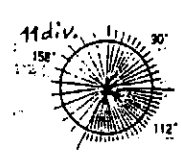
<p>D</p>	<p>Indexing instruction</p> <p>Uniform indexing of circumference (See Fig. A)</p> <pre> N1 A 360. D91 ;   2 A 360. D77 ;   3 A 360. D111 ;   4 A 360. D231 ;   5 A 360. D1231 ; </pre> <p>Uniform indexing of arc (See Fig. B)</p> <pre> N1 A 90. D13 ;   2 A 112. D23 ;   3 A 158. D11 ; </pre> <div data-bbox="1250 441 1477 640" style="float: right;"> <p>Fig. A</p>  </div> <p style="text-align: right;">Uniform indexing into each division</p> <div data-bbox="1201 840 1477 1039" style="float: right;"> <p>Fig. B</p>  </div> <p style="text-align: right;">Uniform indexing into each division</p>
<p>P</p>	<p>1) This is used for calling frequency of the sub-program.</p> <pre> N1 M98 P2 1010 </pre> <div style="margin-left: 100px;"> <p>└───┬────────────────── Sub-program 0 no.</p> <p>└───┬────────────────── Repeating frequency</p> </div> <p>2) Dwell time</p> <pre> N1 G04 P1000 </pre> <div style="margin-left: 100px;"> <p>└────────────────── This indicates a dwell time of 1 second.</p> </div>

8. Explanation of control board

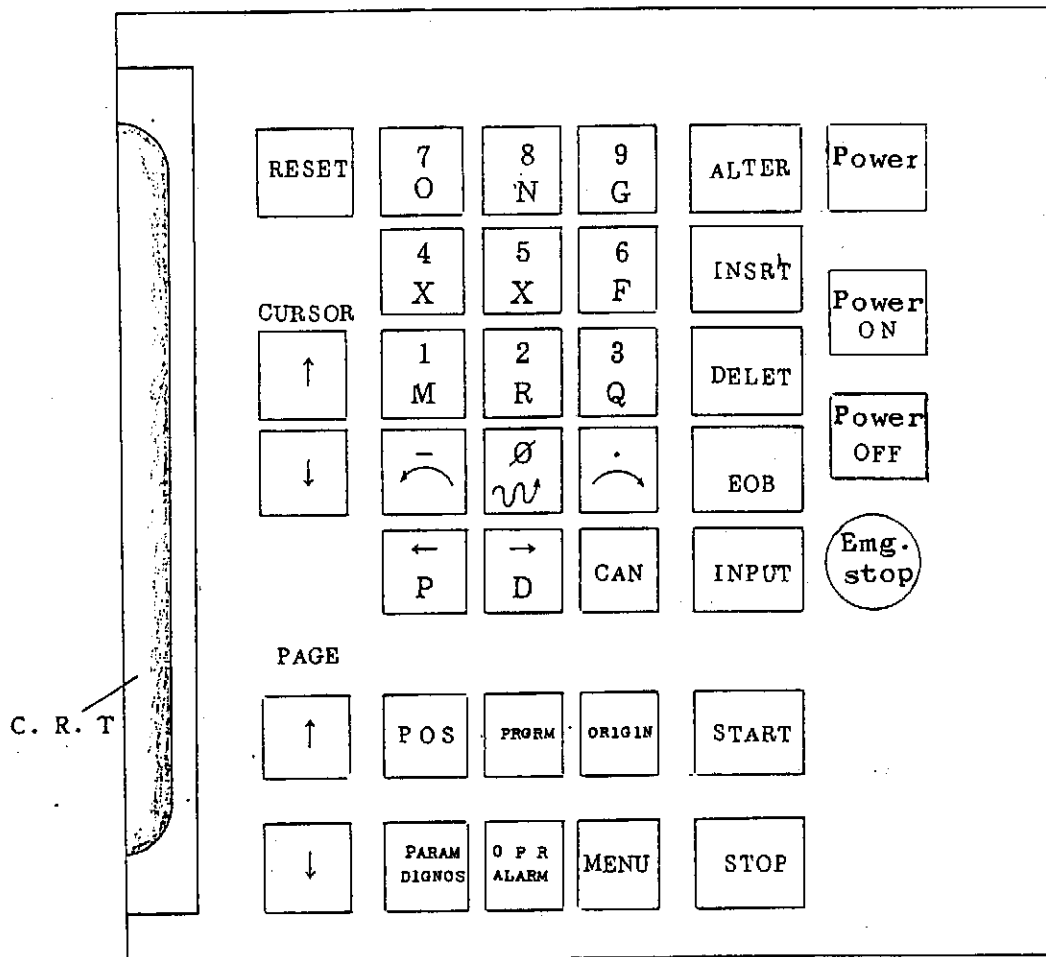

8-1

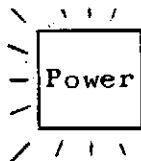

When this lamp lights, it is indicated that the power is supplied to the 9000DC. If the lamp does not light,

- 1) confirm the input power source, and
- 2) confirm whether the breaker in the control board is turned to "OFF" or not. If turned to "OFF", set it to "ON".

8-2

Power  
ON

Push this button after confirming that the power is supplied to the 9000DC. After a little while, literatures will be indicated on the C.R.T. In the event when NOT READY or ALARM is indicated at the left underside of the C.R.T. in this instance, there may be a trouble, and remedy it referring to the following table.

NOT READY:	Check the emergency stop for being functioning.
AIR:	Check the braking air for being connected, and the pressure of air for being dropped.
ALARM:	Refer to the separate "Instruction Manual" and "Maintenance Manual".

8-3

Power  
OFF

When the power OFF button is pushed, the entire system is stopped.

8-4

Emeg.  
stop

The circular table is temporarily stopped when the emergency stop button is pushed, and it is restored to the normal condition when the button is pulled.

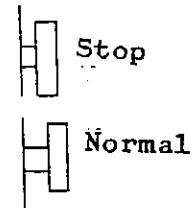

8-5

OPR  
ALARM

Operator's panel button









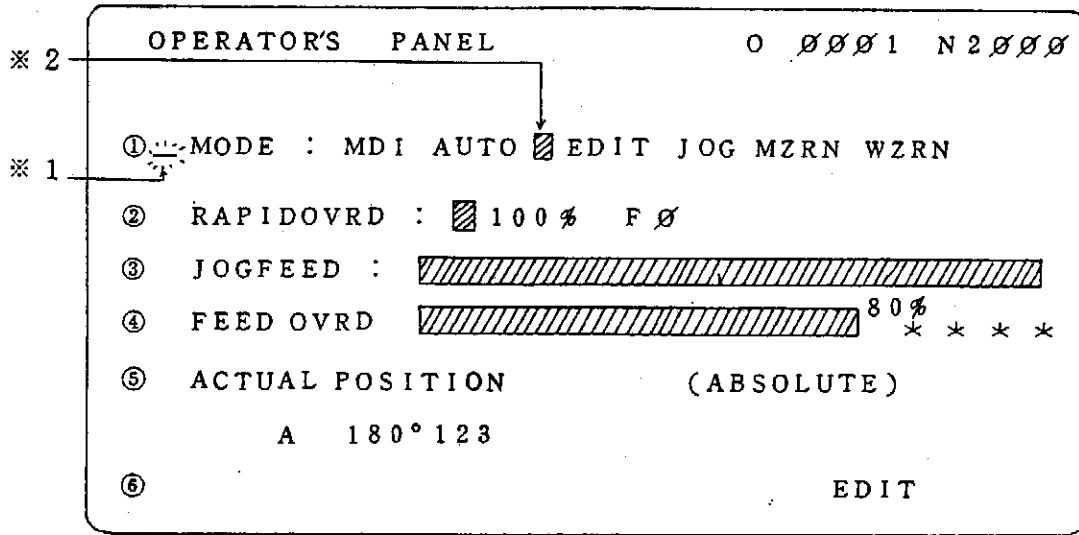

When this button is pushed and PAGE   keys are operated, the following three pictures will appear.

Fig 1-1





- \*1 The blinking cursor  can be moved vertically to a desired position such as ① → ② → ③ → ④ ..... by operating the arrowed buttons CURSOR  .
- \*2 The  mark can be shifted laterally by operating the   keys to bring about a desired situation.

8-5-1 Mode selection: Mode ①

\_MODE : MDI  AUTO EDT JOG MZRN WZRN

This is a selection switch which gives an instruction for mode of operation.

Mode	Function
MDI	(i) This mode enables execution of a program registered in the memory.  (ii) This mode enables execution of program no. search and sequence no. search of the program on the memory.

Mode	Function
MDI (cont'd)	(iii) This mode enables starting and temporary stopping of the program by operating <span style="border: 1px solid black; padding: 2px;">START</span> , <span style="border: 1px solid black; padding: 2px;">STOP</span> keys on the MDI panel.
AUTO	(i) This mode is used when the automatic operation is performed. When a start signal is received from outside, FIN signal is outputted from the 9000DC.
EDT (edit)	This mode enables (i) registration of program in memory, (ii) remedy, insertion, and deletion of program, (iii) punching out of program on memory and other operations regarding edit.
JOG (jog)	This mode enables (i) jog feeding.
MZRN (M zero return)	This mode enables (i) return to manual reference point. 
WZRN (W zero return)	This mode enables (i) return to manual work zero point. 

8-5-2 Rapid feed over-ride: RAPID OVRD ②

100 % F 0

This enables change of rapid-feed speed, however, the mark should be fixed at the  100% side in this machine.

8-5-3 Jog feed: JOG FEED ③

(1) Adjust the mode selection switch to JOG position.

MODE : MDI AUTO EDT  JOG MZRN WZRN

(2) Select and determine the jog feed speed.

JOG FEED : 126 DEG. /MIN



\* \* \* \* \*

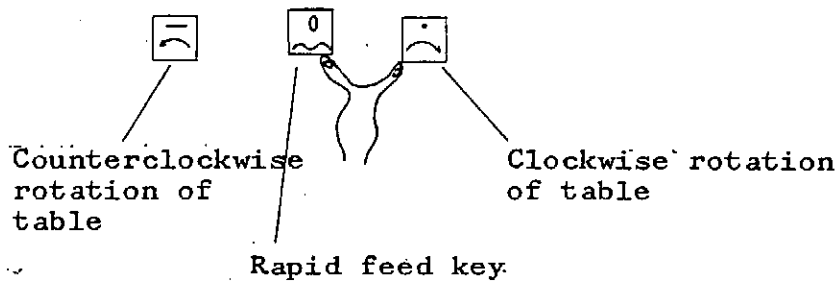



8-5-4 Operator's panel (continued)

When PAGE   keys are pushed in the picture of Fig. 1-1, the picture as shown in Fig. 1-2 will appear.

Fig 1-2

OPERATOR'S PANEL		O	ØØØ1	NØØØ1
*2	BLOCK SKIP	: <input checked="" type="checkbox"/> OFF		ON
	MACHINE LOCK	: <input checked="" type="checkbox"/> OFF		ON
	DRY RUN	: <input checked="" type="checkbox"/> OFF		ON
*1	PROTECT KEY	: PROTECT <input checked="" type="checkbox"/> RELEASE		

\*1 This is the most important item which prevents significant programs etc. from being deleted or changed by mistakes. However, it is recommended to release this item (  RELEAS as seen in the picture) until you become experienced in operating, so the picture of Fig. 1-2 should be used as it is.

\*2 Skip (jump over without executing) a block including / slash ( / will appear when the  key is pushed two times)

OFF: Effective, ON: Ineffective (Refer to P-E instruction Manual Page .)

#### 8-5-5 Alarm indication



When the PAGE   keys are further pushed in the picture of Fig. 1-2, contents of alarm will appear as shown in Fig. 1-3. Refer to FANUC P-E Instruction Manual for details.

Fig 1-3

```
ALARM MESSAGE                                O ØØØ2
P/S ALARM : Ø1Ø
```

Refer to the List of alarm in page 65 of the P-E Instruction Manual.

As for Fig. 2-2 and Fig. 2-3, refer to page 80 of the FANUC P-E Instruction Manual.

Operate the PAGE   keys to let the picture of Fig. 2-1 appear.

9-5 Registration of program NO. and sequence NO.

In case when other program has already been registered and this program is desired to be left as it is, make new program according to the following procedure.

Key operation in newly making -00005 address.

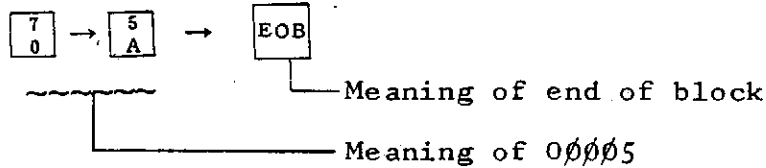

Fig 2-4

```
PROGRAM
O 0 0 0 5 ;
N 1
%
```

Sequence NO. 1 waits the next angle setting at the program NO. 0 5 as shown in Fig. 2-4.

(In the event when the address NO. 5 of 0 has already been registered, P/S alarm 73 will be indicated. In this case, you are going to register the same program NO. as that having been registered in 073.

Release the alarm by pushing the reset key  RESET  , then make new 0 address such as 0 6, 0 7, and so on).

## 9-6 Programming by menu system

After the state of Fig. 2-4 has been set, there provided the menu system which simplifies programming procedures.

### 9-6-1 Calling and confirming G code

Push the keys   and  in this sequence, numbers and meanings of all G functions used in 9000DC will be displayed.

Fig 2-5

```
PROGRAM                00005  N00000
G00 : RAPID
G01 : LINEAR IPL.
G04 : DWELL
G08 : CONTINUOUS BLOCK OPERATION
G09 : SINGLE BLOCK OPERATION
G10 : TABLE UNCLAMP
```

### 9-6-2 Example of programming

The sample machining as shown in the right figure (Fig. 2-6) will be programmed according to the menu system.

- a) Restore the picture to the state of Fig. 2-4, and operate keys according to the following procedures.

State of Fig. 2-4 can be restored by  key.

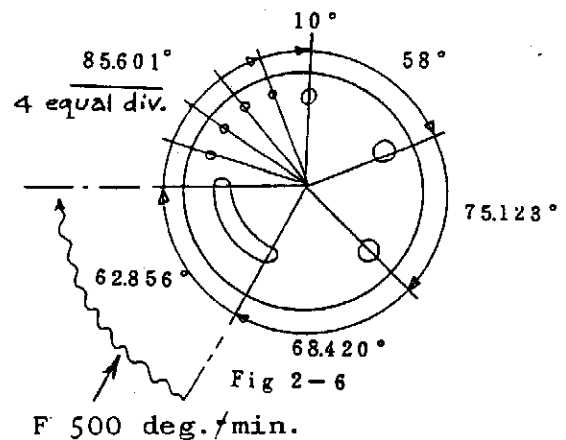

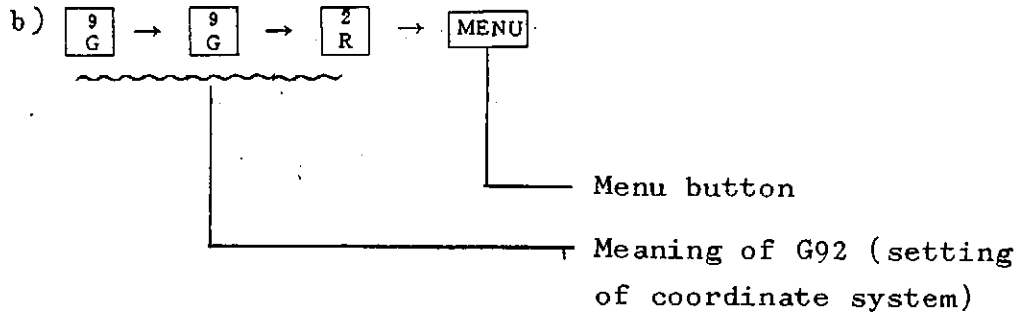

When keys G92 MENU are pushed, the following picture will be displayed. Then, input 0 degree first.

Fig 2-7

```

PROGRAM                                00005 N0001
00005
N 1
%
G 92 : PROGRAMING ABSOLUTE ZERO POINT
G 92      G      G
A :

```

Setting of co-ordina system

c) A (Angle ; ) at the upper part of the picture is blinking (waiting for pushing keys).

The coordinate system of the start position is written as 0 deg. in the picture as follows:



Fig 2-8

```

PROGRAM
00005
N 1      G 92  A0;
N 2

```

- d) In order to successively rotate the table by 58 degrees at the quick-feed speed, push keys in the following sequence and the picture of Fig. 2-9 will be displayed.

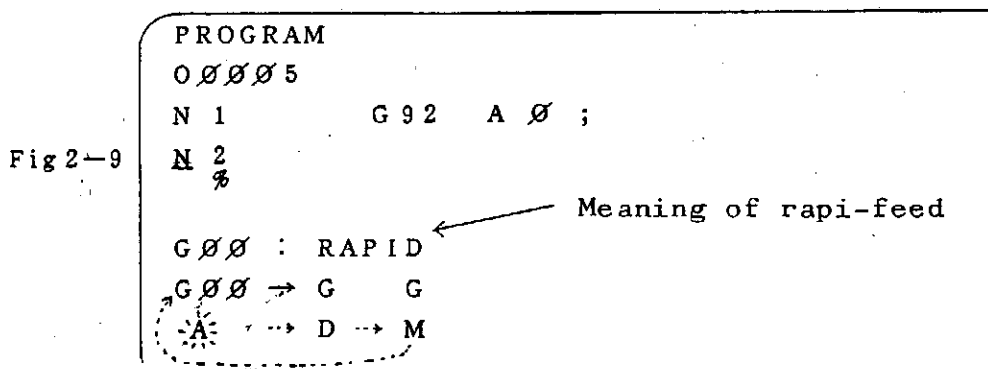
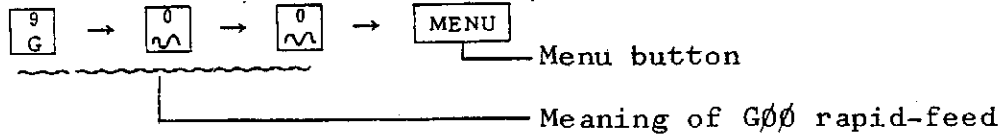

- e) In order to write that incremental rapid-feed by 58 degrees is desired, push keys in the following sequence.

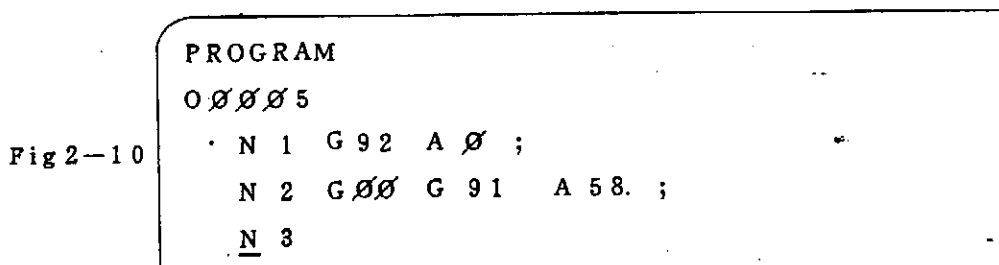
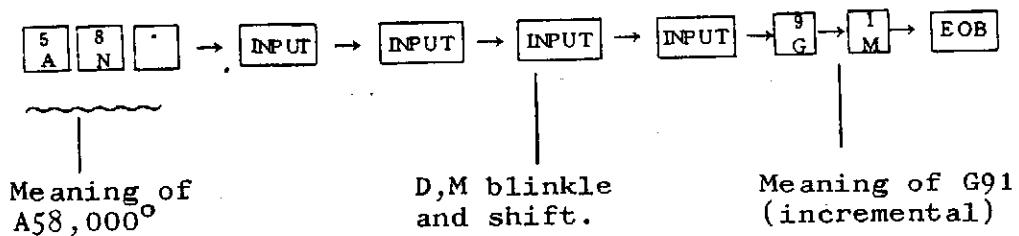

f) In order to further execute rapid-feeds by  $75.123^\circ$  and  $68.420^\circ$ , operation of G code is not necessary because they belongs to the same G00. Push the **MENU** key only, and the following picture will be displayed.

Fig 2-11

```

PROGRAM
00005
  N 1 G 92 A 0 ;
  N 2 G 00 G 91 A 58
  N 3                G G G
                    *A* D F
                    M P R Q ;
  
```

g) At this stage, push keys in the following sequence.

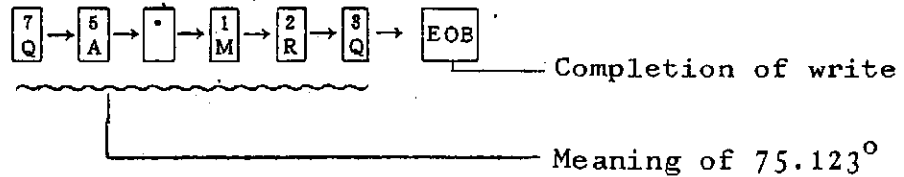

h) Then, push the **MENU** key similarly, and push keys in the following sequence.

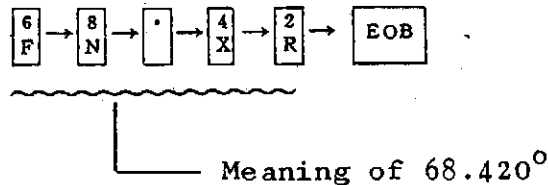

i) In the next stage, it is necessary to designate the feed speed of 500 deg./min. in the cutting feed range of 62.856 deg., so that the above code should be changed to G01 code. Push keys in the following sequence.

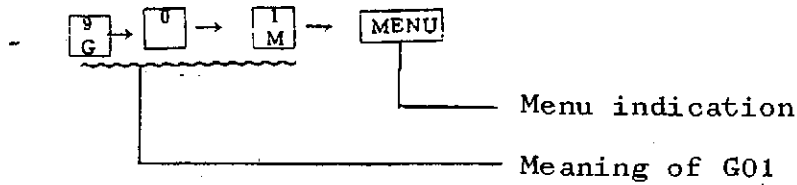

And the following indications will be displayed at the lower part of the picture.

```

G Ø 1 : LINEAR IPL
G Ø 1 : G      G
A      D      F
M

```

j) Push keys in the following sequence,

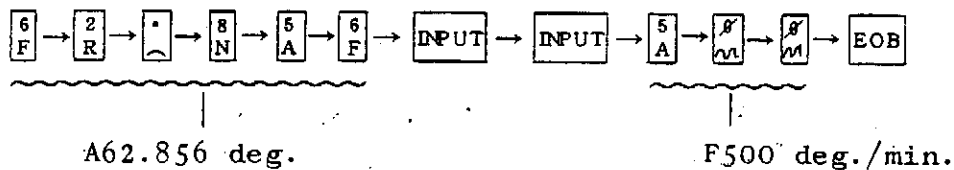

then the following indications will be displayed

```

N'5 G01 A62856 F500 ;

```

k) The next is the block in which 85.601 degrees are equally divided into four. Since this dividing is desired to be executed at the rapid-feed, push keys in the following sequence.

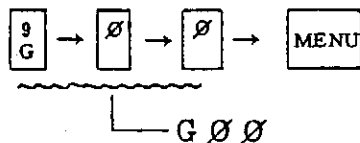

Then, push keys in the following sequence..

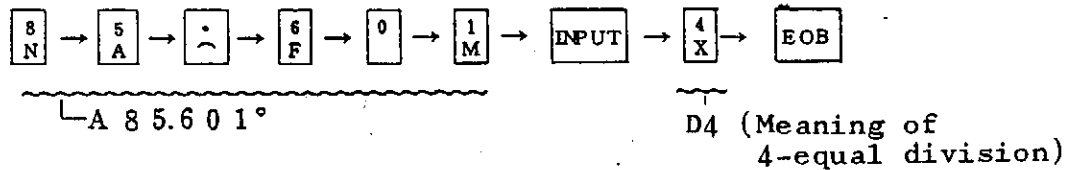

- 1) Since the last block provides the function where the program rotates the table by 10 degrees and returns to the origin, push keys in the following sequence.

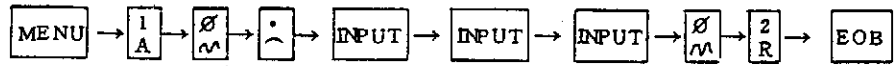

Meaning of A10<sup>0</sup>00

M02 (Meaning of completion of all blocks)

- m) Push the **RESET** key to return the cursor to the beginning of the program. Now, the sample machining of Fig. 2-6 has been completed. Operate the circular table to check the program for being correctly programmed.

## 10. Manual confirmation of function (MDI)

### 10-1 Zero-point return

Push the **OPR ALARM** key again.

Fig 1-1

OPERATOR'S PANEL.



MODE ; MDI AUTO EDIT JOG MZRN WZRN

Restore the picture of program to that of Fig. 1-1 again, bring the mark to the location of MZRN (zero-point return). Operate the **P** **D** keys and continue to push the right-side operation key until the circular table stops.

Note: A position at which the table stops is the zero point, and confirm it on the scale.



## 10-2 Confirmation of function by operating circular table

In order to manually operate the circular table in accordance with the program, it is necessary to set the mode at MDI in the picture of Fig. 1-1. Push the   keys again to bring the  mark to the location of MDI.

OPERATOR'S PANEL

MODE ;  MDI AUTO EDIT JOG MZRN WZRN

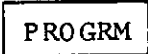
Then, push the  key to change this picture to the program picture executed in Chapter 6.

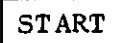
The table will operate one by one block when the  key is pushed, so confirm that the contents of program coincide with the function of circular table.





## 11. Practical application of program

### Key operation



The programming procedures described hereunder should be performed with reference to the pictures of Fig. 1-1 to Fig. 2-1 in Chapter 6.

### ① Angular indexing









N 1  →  →  → MENU →  → INPUT → INPUT →

Coordinate system

 →  → EOB

Incremental

N 2  →  →  → MENU →  →  →  → EOB

Rapid feed

② Circular arc cutting

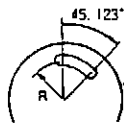

N 1 Same block as N1 of example 1

N 2  $G \rightarrow \emptyset \rightarrow 1 \rightarrow \text{MENU} \rightarrow 4 \rightarrow 5 \rightarrow \cdot \rightarrow 1 \rightarrow 2 \rightarrow 3$

Cutting feed

$\text{INPUT} \rightarrow \text{INPUT} \rightarrow 5 \rightarrow \emptyset \rightarrow \emptyset \rightarrow \text{EOB}$

Meaning of F500  
deg./min.

③ Angular uniform indexing

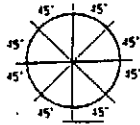

N 1 Same block as N1 of example 1

N 2  $G \emptyset \emptyset \text{MENU} \rightarrow 4 \rightarrow 5 \rightarrow \cdot \text{INPUT} \text{INPUT}$

$\emptyset 2 \text{EOB}$

M02 (Completion of program and  
calling head of program)

④ Irregular indexing

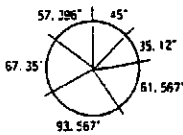

N 1 Same block as N1 of example 1

2  $G \rightarrow \emptyset \rightarrow \emptyset \rightarrow \text{MENU} \rightarrow 4 \rightarrow 5 \rightarrow \cdot \rightarrow \text{EOB}$

3  $\text{MENU} \rightarrow 3 \rightarrow 5 \rightarrow \cdot \rightarrow 1 \rightarrow 2 \rightarrow \text{EOB}$

4  $\text{MENU} \rightarrow 6 \rightarrow 1 \rightarrow \cdot \rightarrow 5 \rightarrow 6 \rightarrow 7 \rightarrow \text{EOB}$

5  $\text{MENU} \rightarrow 9 \rightarrow 3 \rightarrow \cdot \rightarrow 5 \rightarrow 6 \rightarrow 7 \rightarrow \text{EOB}$

6  $\text{MENU} \rightarrow 6 \rightarrow 7 \rightarrow \cdot \rightarrow 3 \rightarrow 5 \rightarrow \text{EOB}$

7  $\text{MENU} \rightarrow 5 \rightarrow 7 \rightarrow \cdot \rightarrow 3 \rightarrow 9 \rightarrow 6 \rightarrow \text{INPUT} \rightarrow$

$\text{INPUT} \rightarrow \text{INPUT} \rightarrow \emptyset \rightarrow 2 \rightarrow \text{EOB}$

5) Incremental and absolute indexing

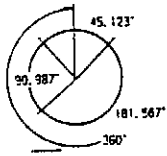

N 1 Same block as N1 of example 1

```

2 G Ø Ø MENU 4 5 . 1 2 3 EOB
3 MENU 1 8 1 . 5 6 7 EOB
4 MENU 9 Ø . 9 6 7 EOB
5 G 9 Ø MENU 3 6 Ø . INPUT → INPUT
    
```

~~~~~ Absolute instruction

```

INPUT Ø 2 EOB
    
```

~~~~~ M02 (Completion of program)

Q Ø Ø Ø 1 ; ← Main program

6) Use of sub-program

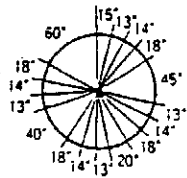

N 1 Same block as N1 of example 1

```

2 G Ø Ø MENU 1 5 . EOB
3 MENU INPUT INPUT 9 8
    
```

~~~~~ M98 (Repeating function)

```

INPUT 2 EOB
    
```

~~~~~ P2 (To sub-program No. 2)

```

4 MENU 4 5 . EOB
5 MENU INPUT INPUT INPUT 9 8
   INPUT 2 EOB
6 MENU 2 0 . EOB
7 MENU INPUT INPUT INPUT 9 8 INPUT 2 EOB
8 MENU 4 0 .
9 MENU INPUT INPUT INPUT 9 8 INPUT 2 EOB
10 MENU 6 0 . INPUT INPUT INPUT
    0 2 EOB
    
```

Continued

0 0 0 0 2 ; ← Sub-program

N 1 G Ø Ø MENU 1 3 . EOB  
 2 MENU 1 4 .  
 3 MENU 1 8 . INPUT INPUT INPUT 9 9 EOB

⑦ Reverse indexing

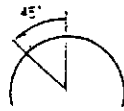

N 1 Same block as N1 of example 1  
 2 G Ø Ø MENU - 4 5 . EOB

Reversing symbol

⑧ Equi-speed rotation

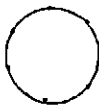

When the ST is pushed while pushing the key or key under the JOG mode, the table will continue to rotate at an equi-speed.

A feeding speed of this rotation is determined by the ③ JOG FEED in Fig. 1-1.

⑨ Circular arc uniform indexing

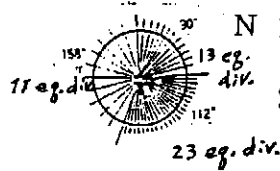

N 1 Same block as N1 of example 1  
 2 G Ø Ø MENU 9 0 . INPUT  
 1 3 EOB

Meaning of D13

3 G Ø Ø MENU 1 1 2 . INPUT  
 2 3 EOB

4 G Ø Ø MENU 1 5 8 . INPUT  
 1 1 EOB

5 MENU INPUT INPUT INPUT Ø 2 EOB

MØ2

⑩ Circumference uniform indexing

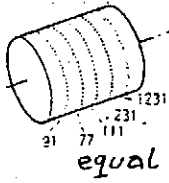

N 1 Same block as N1 Of example 1

|   |      |       |       |       |       |       |   |   |     |     |
|---|------|-------|-------|-------|-------|-------|---|---|-----|-----|
| 2 | MENU | 3     | 6     | 0     | .     | INPUT | 9 | 1 | EOB |     |
| 3 | "    | "     | "     | "     | "     | "     | 7 | 7 | EOB |     |
| 4 | "    | "     | "     | "     | "     | 1     | 1 | 1 | EOB |     |
| 5 | "    | "     | "     | "     | "     | 2     | 3 | 1 | EOB |     |
| 6 | "    | "     | "     | "     | "     | 1     | 2 | 3 | 1   | EOB |
| 7 | MENU | INPUT | INPUT | INPUT | INPUT | Ø     | 2 |   | EOB |     |

⑪ Sexagesimal input

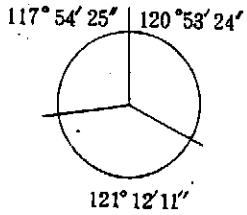

N 1 Same block as N1 of example 1

|   |       |       |       |       |   |   |   |   |   |       |   |   |     |                                     |
|---|-------|-------|-------|-------|---|---|---|---|---|-------|---|---|-----|-------------------------------------|
| 2 | G     | Ø     | Ø     | MENU  | 1 | 2 | 0 | . | 5 | 3     | 2 | 4 | EOB |                                     |
|   | INPUT | INPUT | INPUT | INPUT | 2 | Ø |   |   |   |       |   |   | EOB |                                     |
|   |       |       |       |       |   |   |   |   |   |       |   |   |     | G20<br>(Sexagesimal<br>instruction) |
| 3 | MENU  | 1     | 2     | 1     | . | 1 | 2 | 1 | 1 |       |   |   | EOB |                                     |
| 4 | MENU  | 1     | 1     | 7     | . | 5 | 4 | 2 | 5 | INPUT |   |   | EOB |                                     |
|   | INPUT | INPUT | Ø     | 2     |   |   |   |   |   |       |   |   | EOB |                                     |

## 12. Registration into memory, search, and deletion of program

### 12-1 Registration of program

- a) Select the mode of  EDIT.
- b) Push the  key.
- c) Input a desired program No. and push the  key.  
When 0 10 is to be newly registered, push keys in the following sequence.
- d) If the indication ALARM is displayed, this informs you of double-registration. Push the  key to register the above program in other address (0 11, ..... ) again.

### 12-2 Search and confirmation of program No.

When a program which has already been registered is to be called, perform the same procedures as described in a) and b) paragraph 9-1, and the following procedure c).

- c) Input a desired program, then push the  key.

Example:

When 0 1 address which has already been registered is to be called, push keys as follows:

then, the program in 0 1 will be displayed on the C.R.T., or push keys as follows:

then, the list of programmed No. and remaining memory capacity etc. will be displayed. Refer to page 100 of the P-E Instruction Manual.

### 12-3 Deletion and erase of program

#### Deletion of program

This operation is used for the purpose of deleting a program which is registered in the memory.

- (1) Select the mode of EDIT.
- (2) Push the PRGRM key.
- (3) Set the address to 0.
- (4) Input the program No.
- (5) Push the DELET key and the inputted program No. will be deleted.

#### Deletion of all programs

This operation is used for the purpose of deleting all programs which are registered in the memory.

- (1) Select the mode of EDIT.
- (2) Push the PRGRM key.
- (3) Set the address to 0.
- (4) Push keys in the following sequence.

- 9 9 9 9 9 DELET

13. Description of keys INSRT ; Insert, ALTER ; Alter,  
and DELET ; Delete

13-1 Key INSRT ; Insert (Insertion of word)

Example: When D2 is to be inserted

↓

N200 G01 A100 F500 ; N300 A200 D8 ; N400.....

↑

└─ this location is serched.

When D2 is to be inserted immediately after F500 in N210 block, perform the same procedures as described in a) and b) of paragraph 12-1, and the following procedures c) and d).

c) Operate the CURSOR ↑ ↓ keys to bring the cursor  to the location of F500.

d) Push the D 2 INSRT keys. Thus, the inserting operation is completed.

13-2 Key ALTER : Alter (Alteration of word)

Example: A100 is to be altered to A15.

N100 G92 A0 ; N200 G01 A100 F500 ; N300.....

↑

to be altered to A15

When A100 is to be altered to A15 in N200 block, perform the same procedures as described in a) and b) paragraph 9-1, and the following procedures c) and d).

c) Operate the CURSOR ↑ ↓ keys to bring the cursor  to the location of A100.

d) Push keys in the following sequence, thus A100 can be altered to A15.

5 1 5 . ALTER

└─ Meaning of A15

13-3 Key **DELET** : Delete (Deletion of word)

Deletion of word

N100 G92 A0 ; N200 G01 A100 F500 ; N300 .....

↑  
N200 is to be deleted

- (1) Search the word to be deleted.
- (2) Push the **DELET** key.

Deletion down to EOB

Word which is searched / scanned at present  
(which the cursor is indicating)

N200 G01 A100 F500 D2 ; N300 .....

← Region to be deleted →

When the above region is to be deleted, push the **EOB** ,  
**DELET** keys in turns and words down to EOB will be  
deleted. The cursor will shift to a location beneath  
the address of the next word.

Deletion of several blocks

From the word indicated at present down to the block of  
prescribed sequence No. are deleted.

Word which is searched/  
scanned at present (which  
the cursor is indicating)

N2233 is inputted

.....A10 ; A15 F100 ; .....D12 ; N2233 A12 ; N3344 .....

← Region to be deleted →

down to EOB

- (1) Input the address N.
- (2) Input the sequence No. 2233.
- (3) Push the DELET key and blocks down to the block of N2233 are deleted. The cursor will shift to a location beneath the address of the next word.

