

PROCEDURES TO CHANGE NPU DRILL CHUCK HEAD

1. Remove pullstuds from holder.
2. Turn cap bolt (A) CCW for one full turn.
3. Put spacer (B) into pullstud hole.
(spacer size varies per tool)
4. Put pullstuds back in holder & tighten it until it disengage drill chuck head from holder.
Taper contact at (C) will disengage
5. Remove pullstud, spacer, cap bolt & drill chuck head from holder.
6. Replace NPU head.
Recommended tightening torque on cap bolt (C)
NPU8: 9 lbs-ft NPU13: 12 lbs-ft

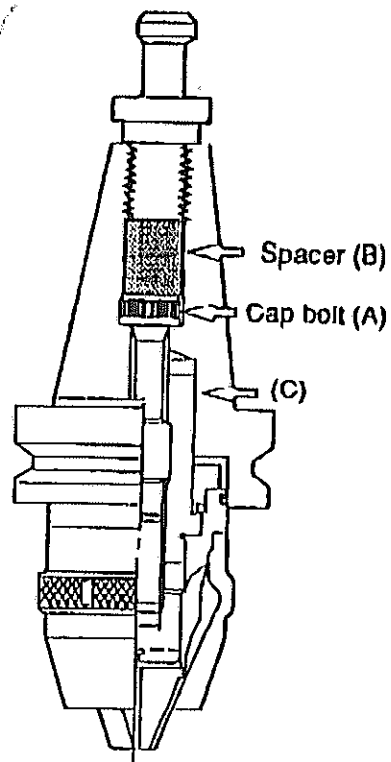

PROCEDURES TO CHANGE JAWS ON DRILL CHUCK HEAD

1. After drill chuck head is taken out from holder, take o-ring out from head.
2. Put the head in scroll chuck by holding part (D).
3. Turn part (E) CCW direction with wrench, then cap will come out from head.
*If cap will not turn, heat the head with electric hot plate. This will dissolve tight lock glue inside.

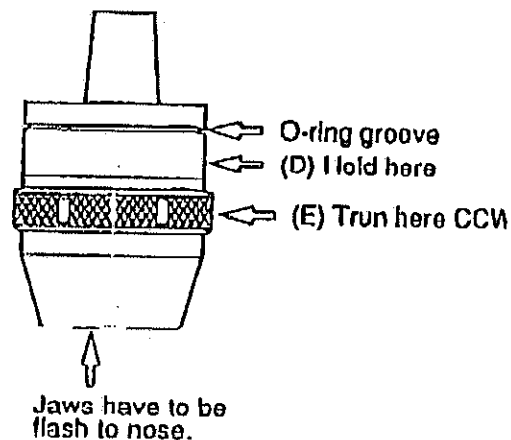

PARTS FOR NPU

Only jaws (3 pcs/set) and head are available.

Jaws	A	B	C	D
SP-08060	.079 2.0mm	.118 3.0mm	.343 8.7mm	-
SP-08061	.114 2.9mm	.173 4.4mm	.374 9.5mm	-
SP-08062	.114 2.9mm	.173 4.4mm	.409 10.4mm	-
SP-13060	.118 3.0mm	.173 4.4mm	.484 12.3mm	.059 1.5mm
SP-13061	.134 3.4mm	.197 5.0mm	.484 12.3mm	.059 1.5mm
SP-13062	.134 3.4mm	.197 5.0mm	.524 13.3mm	.098 2.5mm

