

LYNDEX-NIKKEN

SOLUTIONS FOR TODAY'S MANUFACTURING



TOOLHOLDERS



LIVE & STATIC TOOLING



CUSTOM TOOLS



ROTARY TABLES



PRESETTERS



WORKHOLDING



MACHINE TENDING

PRODUCT LINE CATALOG

LYNDEX-NIKKEN

HIGH-PERFORMANCE SOLUTIONS

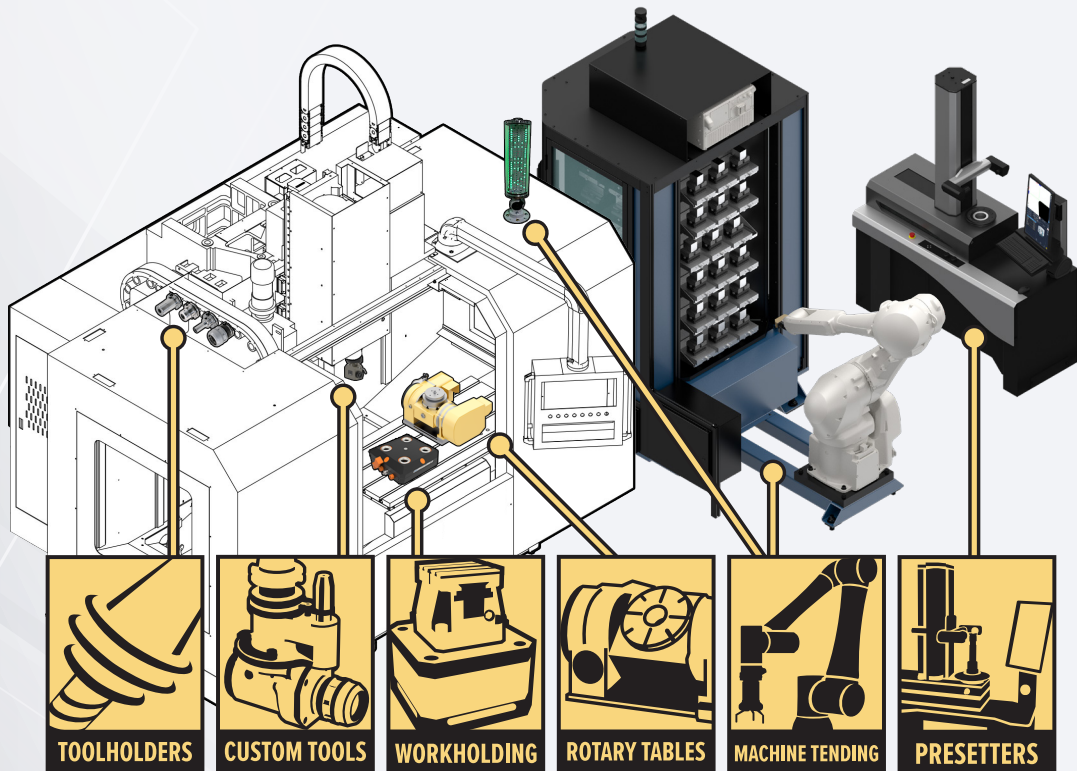

SOLUTIONS FOR MACHINING CENTERS

lyndexnikken.com

(847) 367-4800

DELIVER EXCEPTIONAL RESULTS

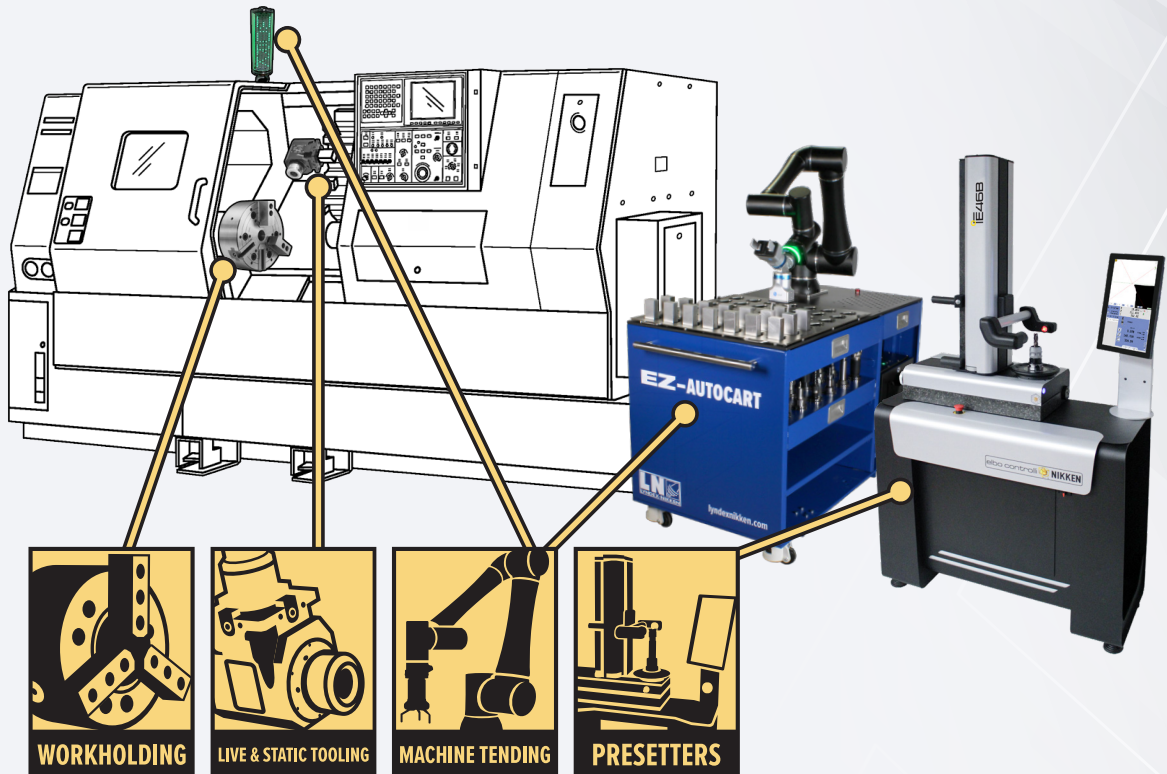

SOLUTIONS FOR TURNING CENTERS

LYNDEX-NIKKEN

ENGINEERED SOLUTIONS

AEROSPACE & DEFENSE

Mission-critical components for aircraft and defense systems

Every aircraft and defense system requires components built to the highest standards, where failure is not an option - beginning with precision manufacturing. Our solutions meet the exacting demands of the global aviation industry. We are trusted by Tier 1 suppliers and top manufacturers to help them build components that protect American soil and support operations abroad.



AUTOMOTIVE

Driving precision in every part

In today's competitive automotive industry, your brand's reputation is built on the reliability of your products. To help you meet the highest standards, our solutions have the utmost precision, rigidity, and durability - designed to eliminate variability and ensure that each part is manufactured with the same high degree of accuracy.



MEDICAL

Precision solutions for complex parts

To ensure the performance and reliability of complex, smaller medical parts, manufacturing requires extreme accuracy and repeatability to hold tighter tolerances. As a leader in micro-precision tooling systems, we have the technology to meet your most demanding medical manufacturing needs.



lyndexnikken.com

(847) 367-4800

FOR EVERY INDUSTRY...

ENERGY & POWER GENERATION

Power starts with powerful machining capabilities

Whether it's power generation or power distribution, efficiency and precision are paramount. Our machine tool accessories feature powerful clamping systems, precise positioning, and big bore through-holes to enhance your manufacturing processes and deliver the dependable performance your customers expect.



JOB SHOPS

Flexibility for your dynamic demands

To adapt to today's fast-evolving manufacturing landscape, you need equipment that can handle high-mix, low-volume jobs. The right machine tool accessories and machine tending solutions can help you balance your budget with your precision requirements, whether you're scaling up or optimizing existing processes.



DIE/MOLD

Precision is a necessity

In die/mold machining, precision isn't just a goal - it's an absolute necessity. We know that every minute and every part counts, and there's no room for costly errors due to tool runout. Our high-performance tooling delivers the precision you need to prevent witness marks and scrapped parts, ensuring your process is as flawless as your final product.



CONSTRUCTION EQUIPMENT

Paving with technology

The construction industry requires robust machining solutions for large, heavy workpieces and tough materials. Our machine tool accessories are designed to streamline your production, helping you achieve superior accuracy, reduce downtime, and minimize waste to maintain profitability.



LYNDEX-NIKKEN

HIGH-PERFORMANCE TOOLHOLDERS



Toolholders engineered to meet today's application-specific demands. Whether you require high-pressure spindle-thru coolant, vibration dampening, precise TIR, or a compact and rigid design - we have you covered.



lyndexnikken.com

(847) 367-4800

HIGH-PERFORMANCE TOOLHOLDERS

Optimize Machine Performance



SK COLLET CHUCK

- TiN bearing nut provides rigidity
- 8° taper angle provides increased gripping force 2-3x greater than traditional ER style
- Guaranteed 5 micron runout at 4 times the diameter



MILLING CHUCK

- Extremely high gripping force
- Rigidity & durability for aggressive machining
- Ideal for roughing, semi-finish, and finishing



VC COLLET CHUCK

- TiN bearing nut reduces friction
- High runout accuracy: 3 microns at 4 times the diameter
- Dampening characteristic for hard milling



SHRINK FIT HOLDER

- Useful for clearance in critical applications
- Pre-balanced up to 25K RPM and comes standard with coolant ports
- Ideal for high-speed applications



MMC COLLET CHUCK

- Ideal for clearance in critical applications and high-speed machining
- Accuracy in small diameter cutting
- No collet nut - draw-in collet clamping for high-precision gripping

LYNDEX-NIKKEN

TAPER PLUS TOOLHOLDERS



TAPER PLUS+

COMBINING TAPER ACCURACY WITH FLANGE RIGIDITY

- Outstanding runout accuracy for longer tool life
- Vibration dampening for increased productivity
- High rigidity for smooth and stable cutting

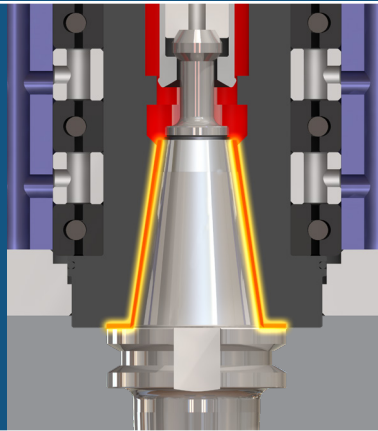

lyndexnikken.com

(847) 367-4800

TAPER PLUS TOOLHOLDERS

Taking Rigidity to the Next Level

- Combines taper accuracy with flange rigidity for smooth and stable cutting.
- Added surface area contact provides 30-40% more rigidity allowing for more aggressive machining.
- Outstanding runout accuracy for longer tool life.
- Vibration dampening for increased productivity.
- Flange contact provides greater support for long length toolholder applications on horizontal machining centers.

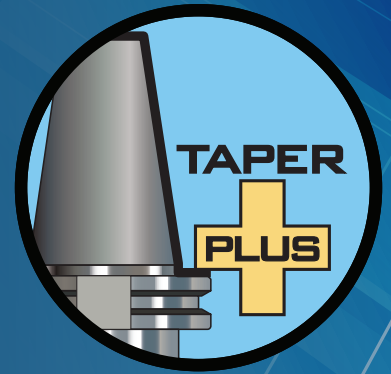

LYNDEX-NIKKEN

SHRINK FIT UNITS & HOLDERS

Available in 220V or 380V

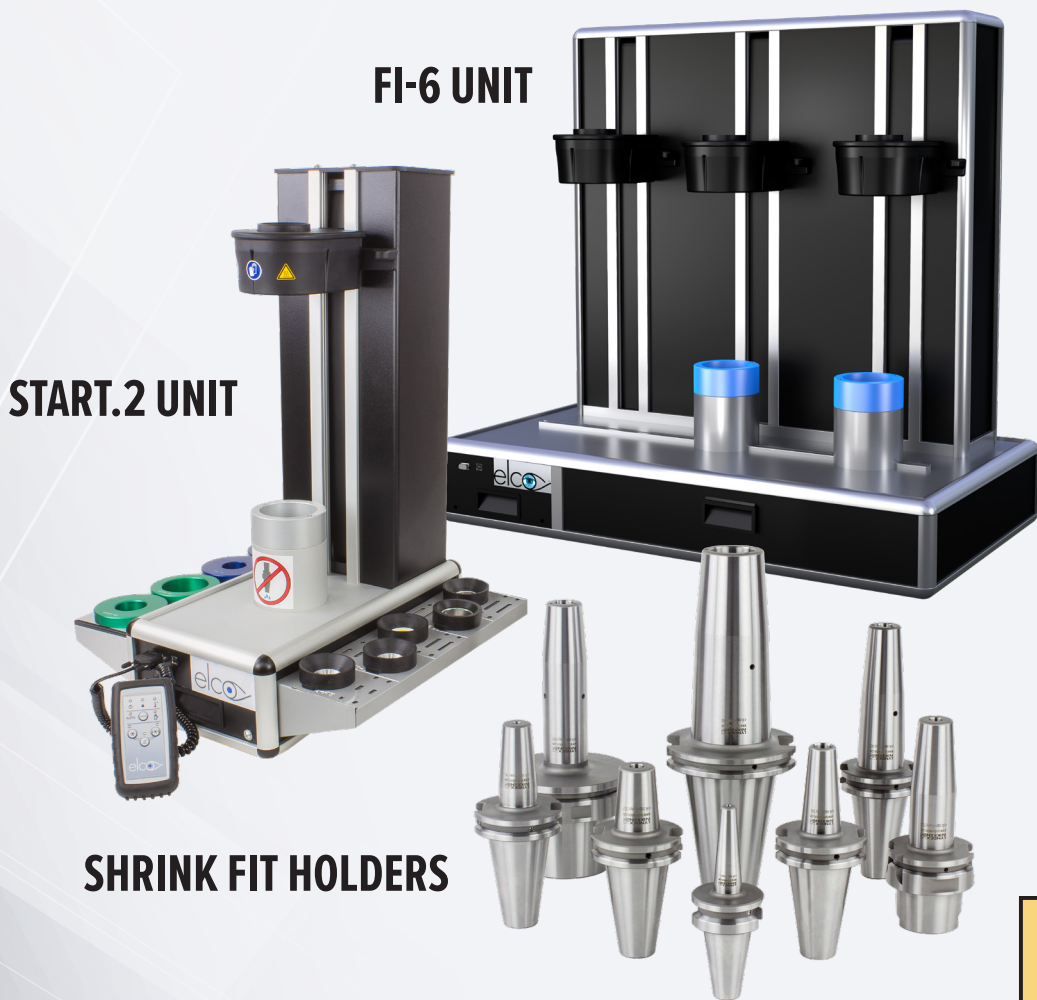

START.2 UNIT

FI-6 UNIT

SHRINK FIT HOLDERS



SHRINK FIT UNITS & HOLDERS

Ultimate Gripping for High Speed and Precision

- 14KW provides high speed shrinking of both HSS and carbide shanks in 2 seconds.
- Automatic detection of cutting tool sizes to eliminate overheating of the toolholder.
- Inductor rotates 180° to easily remove broken tools.
- Optional foot pedal allows heating of tool while keeping both hands free for safety and more control.
- Widest shrinking range available for a desktop unit: 0.079" - 1.575" (Ø 2 - 40mm).
- Unique slide-out control module for easy service or repair within 24 hours.

LYNDEX-NIKKEN

STANDARD TOOLHOLDERS & ACCESSORIES

STANDARD
TOOLHOLDERS



ACCESSORIES



lyndexnikken.com

(847) 367-4800

STANDARD TOOLHOLDERS & ACCESSORIES

Covering All Bases for Machine Tool Accessories

- Widest range of standard ER collet chucks, end mill holders, shell mill holders, tap holders, TG and DA collet chucks, stub mill holders, retention knobs (pull studs), Jacobs taper adapters, and morse taper adapters.
- Accessories include tool clampers, test bars, momimen carbide indexable chamfering & center-drilling tools, chibimomi carbide indexable chamfering & center-drilling tools, and TQW torque wrenches.
- Stocked and distributed from Illinois for fast delivery.

LYNDEX-NIKKEN

LIVE & STATIC TOOLING

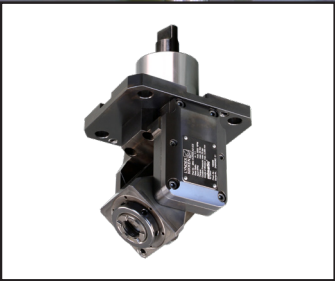
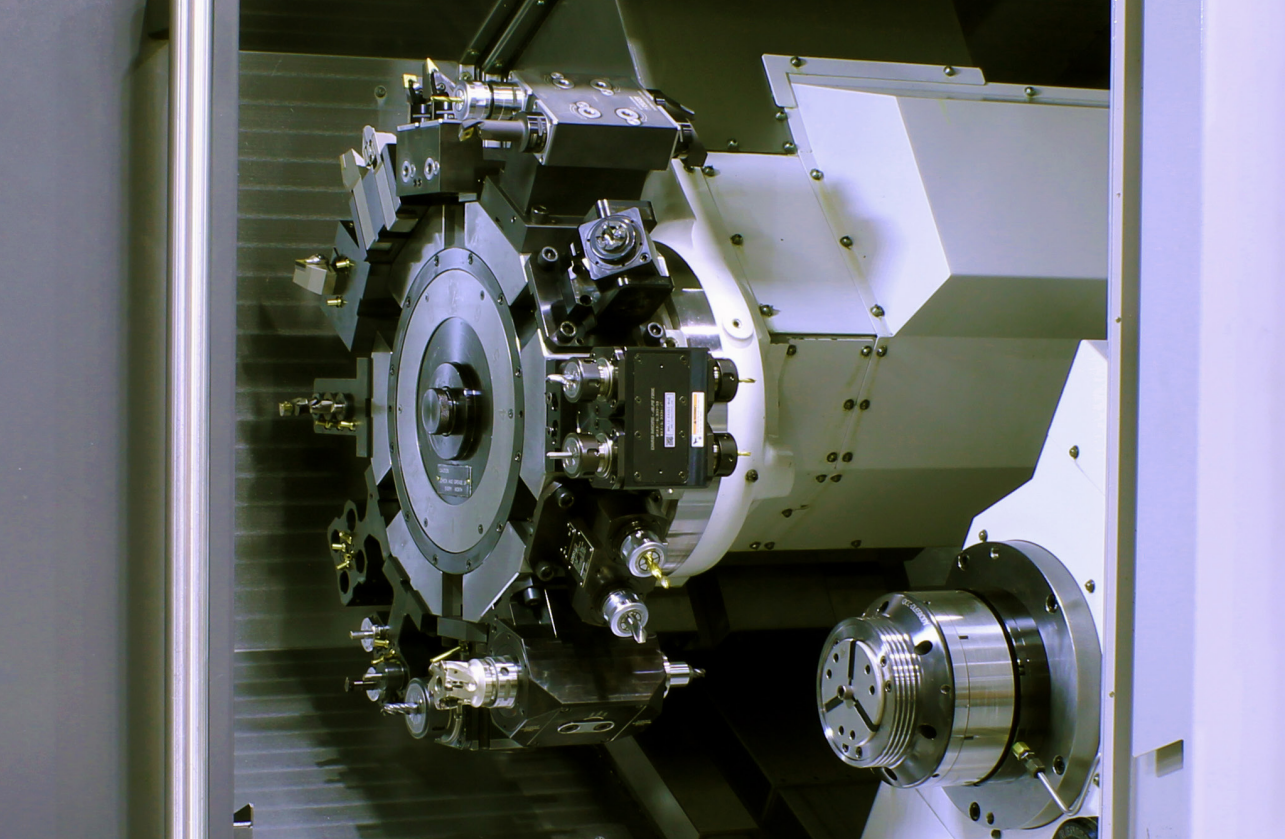

LIVE & STATIC TOOLING

Turns Lathe into Milling Machine - Increase Performance with Unique SK Output System

- Perform multiple operations without the need for changing machines or repositioning the workpiece.
- The precision and stability of our live and static tools produce high-quality parts efficiently and effectively.
- The bearings, gears, and seals of our live tools provide the highest accuracy, rigidity, and stability.
- We offer both live and static tools for a multitude of machine builders, as well as in coolant through, adjustable, and multi-output.



High-Precision Angular Ball Bearings guaranteed concentricity of 0.03mm at 100mm and high rotation speed.



Cyclo-Palloid Toothed Bevel Gears for high torque, smooth running, and low backlash.

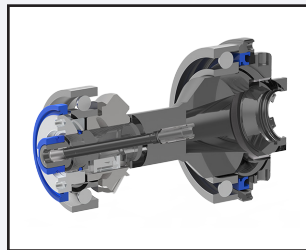

Innovative Sealing System enables dry running at up to 70 bar with reduced heat generation.



Multiple Tooling Interfaces ER collet chucks, PSC polygonal, and quick-change options available.

LYNDEX-NIKKEN

MODULAR & FIXED ANGLE HEADS

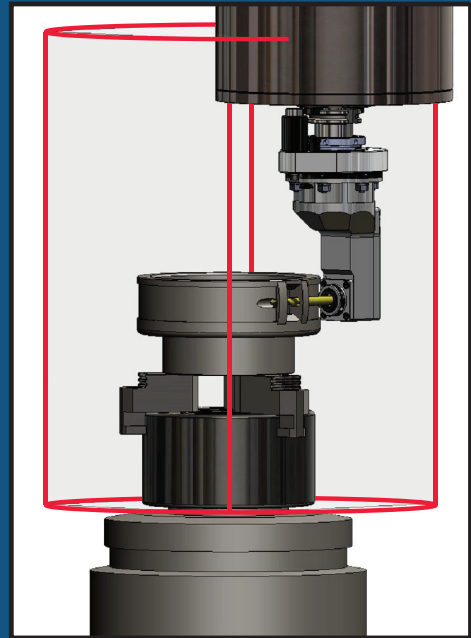

lyndexnikken.com

(847) 367-4800

MODULAR & FIXED ANGLE HEADS

Approaching Complex Parts from All Angles

- Overcomes spatial constraints, access difficult-to-reach areas, and perform complex machining with precision and ease.
- Rigidity and accuracy due to vernier scales and positioning ring, recessed collet seat, and high precision assembly.
- Clearance and ATC verification done by 3D printed angle heads and full 3D model support upon request.
- Offered in multiple styles: standard, offset, high torque, slim, twin spindle, universal, quick change, modular and specials.

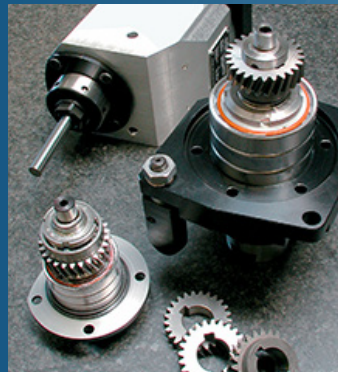

LYNDEX-NIKKEN

ROTARY TABLES

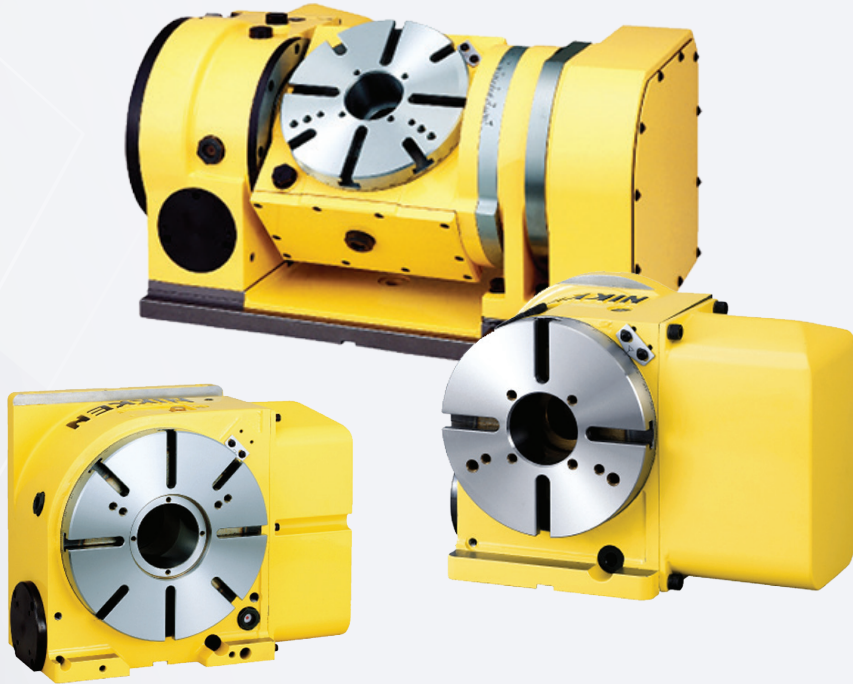

RIGIDITY, ACCURACY, AND DURABILITY IN ROTARY TABLES

Innovative Carbide Worm System

The V grade solid carbide worm screw helps to ensure high rigidity and virtually eliminates wear.

Ion Nitrided Worm Wheel
HV980

Steel Way
HRC58-60

Carbide
Worm Screw

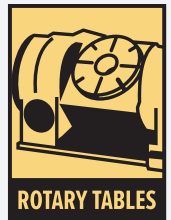

ROTARY TABLES

Manufacture Complex Parts with Increased Productivity and Precision

- Nikken rotary tables are recognized worldwide for their wear-resistance, rigidity, and high-speed rotation.
- Designed and built to provide high accuracy, increased production, and a trouble-free long life.
- Carbide worm system (carbide worm screw, ion nitrided worm wheel, hardened steel bearing surface) ensures high rigidity, increased accuracy, and virtually eliminates wear.
- Full installation and integration services available by Lyndex-Nikken factory-trained U.S. technicians.

LYNDEX-NIKKEN

ELBO CONTROLLI NIKKEN PRESETTERS



lyndexnikken.com

(847) 367-4800

ELBO CONTROLLI NIKKEN PRESETTERS

Streamline Tool Setups Offline

- Maximize uptime, boost accuracy, ensure consistency, and improve overall machining efficiency - for both mills and lathes.
- Thermal stability due to a granite base and column ensure long-term precision.
- Interchangeable spindles eliminate the need for adapters which can introduce additional errors.
- All units come with 100+ of the most common post processors for today's CNC controls.
- Free software updates included for the lifetime of model.



Thermal Stability



Interchangeable Spindles

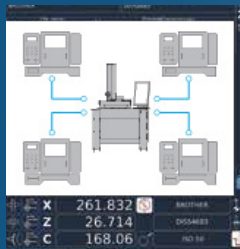

100 Post Processors



Free Software Updates

Scan the QR code to use our
presetter ROI calculator
and discover how fast
you'll see the payback.



LYNDEX-NIKKEN

WORKHOLDING - CLAMPING

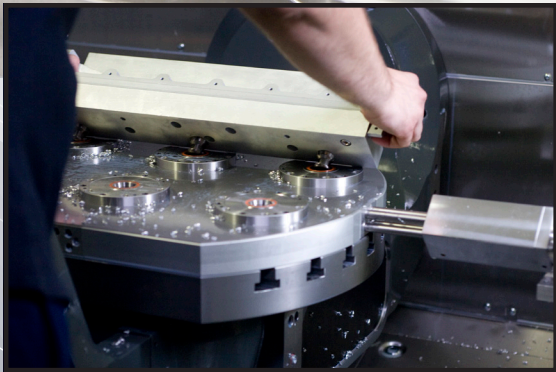

ZERO POINT CLAMPING SYSTEM



lyndexnikken.com

(847) 367-4800

WORKHOLDING - CLAMPING

Flexibility, Diversity, and Accuracy

- Zero Point clamping system is a modern alternative to conventional T-slot table providing quick change setup.
- Modular rail vise provides flexibility in part size and shape for a single part to multiple parts.
- Manual and pneumatic self-center vise provides a solution for today's five-axis machining.
- All workholding is a solution for today but also future proofing for tomorrow's machine tending.

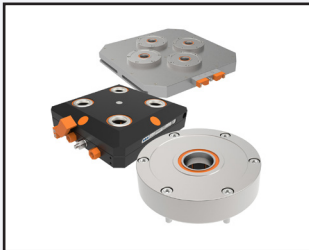

Zero Point System



Manual Rail Vise



Pneumatic Self-Center Vise



Manual Self-Center Vise

LYNDEX-NIKKEN

WORKHOLDING - CHUCKS

**HYDRAULIC
POWER CHUCKS**



**QUICK CHANGE FLEX
COLLET (QCFC) CHUCKS**



CUSTOM DESIGN POWER CHUCKS

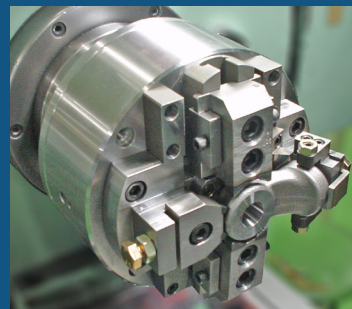
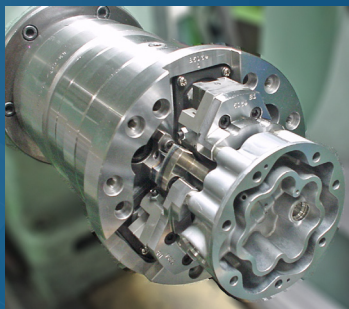
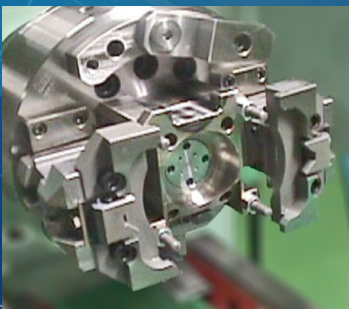

lyndexnikken.com

(847) 367-4800

WORKHOLDING - CHUCKS

Secure and Reliable Clamping

HYDRAULIC POWER CHUCKS:

- Offers excellent concentricity and repeatability, ensuring consistent part quality.
- Provides robust clamping force to accommodate heavy-duty machining applications.
- Minimizes set-up time and changeover.
- Increases machining efficiency and throughput.

QUICK CHANGE FLEX COLLECT (QCFC) CHUCKS:

- Easy mount compact design enables fast collet changes and less change over time.
- Durable, wear resistant collets provide high accuracy due to high clamping force.
- Wide clamping range for a variety of turning center applications.
- QCFC available in smooth, hex, and serrated.

LYNDEX-NIKKEN

MACHINE TENDING SOLUTIONS

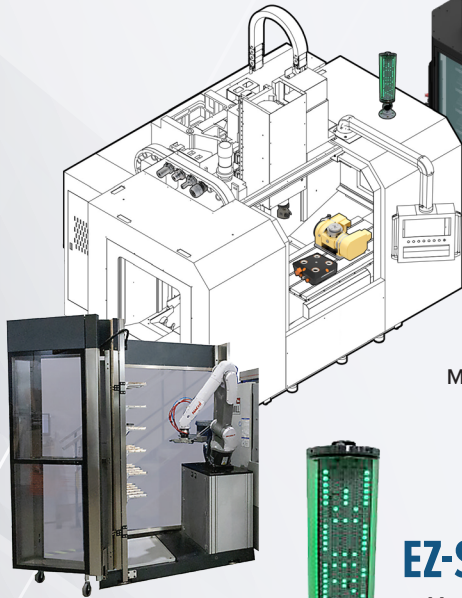

EZ-COB

CNC Machine
Loading Solution



EZ-SMARTTOWER

Machine Tracking System
for ROI Analysis

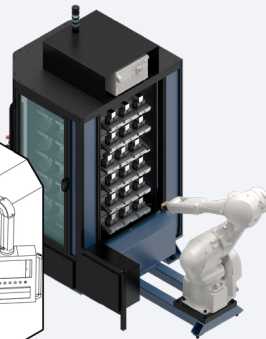

EZ-TEND

Modular CNC Machine
Tending Platform



EZ-BOT

Automatic Work Changer
for CNC Machine

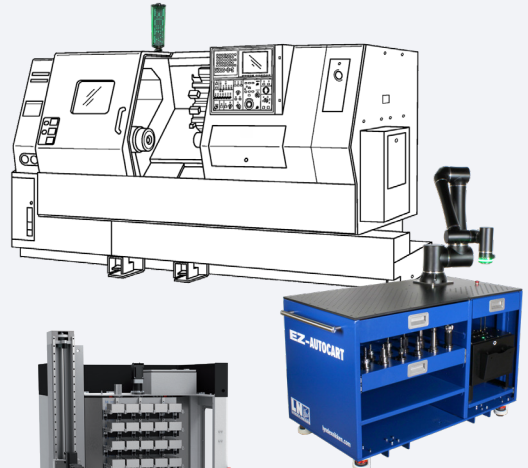

EZ-AUTOCART

Easily Automate CNC
Machine Tending

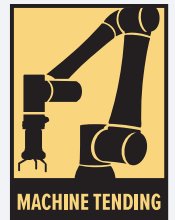

MACHINE TENDING SOLUTIONS

Streamline Operations and Improve Processes

- Machine shops can thrive with a solution for lack of skilled workers and a high burden of costs.
- Modular and scalable products, ideal for high-mix, low volume production, crafted with simplicity in mind.
- NO advanced robotics degree required.
- Easily and seamlessly integrate machine tending while controlling costs and easing job complexities.
- Stress-free entry into Industry 4.0/5.0 and smart factory capabilities.

LYNDEX-NIKKEN

SERVICE & INSTALLATION



lyndexnikken.com

(847) 367-4800

SERVICE & INSTALLATION

Ensure Optimal Performance and Longevity of Equipment

- Providing world-class, factory trained service in the U.S.
- Fully equipped service department with 30+ years of experience enabling complete and timely support.
- Servicing for CNC rotary tables, live tools, angle heads, and toolholders.
- Complete interface and installation on FANUC controller machining centers.

LYNDEX-NIKKEN

OUR PARENT COMPANY NIKKEN

Advanced Technology and Innovation

- Wide range of high performance, reliable, and accurate solutions.
- Products are designed for a variety of applications, processes, and materials across all machine tool platforms and spindles.
- Developing and manufacturing precision CNC and NC tooling systems for over 60 years.



GLOBAL NETWORK

Quality Machine Tool Accessories Where You Need Them

- 15 countries
- Global technical center
- 4 manufacturing plants



1. USA - Lyndex-Nikken



2. Mexico - Herramientas Lyndex-Nikken



3. UK - Nikken Kosakusho Europe



4. Germany - Nikken Deutschland



5. Italy - Vega International Tools



6. France - Procomo-Nikken



7. Sweden - Nikken Scandinavia



8. Spain - Cutting Tools, S.L.



9. Turkey - Nikken Turkey



10. South Korea - Korea Nikken



11. China - Nikken China



12. Singapore - Nikken Kosakusho Asia



13. Thailand - Siam Nikken



14. Indonesia - Nikken Indonesia



** Japan - Nikken Kosakusho Works Ltd.

ABOUT US

At Lyndex-Nikken, our mission is simple: keep you ahead of the competition. We deliver the industry's most advanced machine tool accessories, driven by cutting-edge technology and continuous innovation. Beyond our products, our experienced technicians and product specialists provide unmatched customer service and engineering support.

LYNDEX-NIKKEN

HEADQUARTERS OFFICE

1468 Armour Boulevard, Mundelein, IL 60060
lyndexnikken.com | sales@lyndexnikken.com
Phone: (847) 367-4800 | Fax: (847) 367-4815

MEXICO OFFICE

Herramientas Lyndex-Nikken S.A. de C.V.
Poligono Empresarial Santa Rosa
Av. Hercules #401 B-13
Santa Rosa Jauregui, Queretaro, QRO
Mexico 76220

