

DRILL CHUCKS & MORSE TAPER HOLDERS



DRILL/MORSE



DRILL CHUCKS & MORSE TAPER HOLDERS



DRILL CHUCKS FEATURES

High-Precision, High-Rigidity, Compact Design

Our Drill Chucks feature a unique compact design and small head which prevent the drill from slipping during drilling operations.

- NPU8 is balanced to G6.3 @ 7,000 RPM
- NPU13 is balanced to G6.3 @ 5,000 RPM
- Short compact two-pieces design for flexible replacement of head only
- Maintenance free

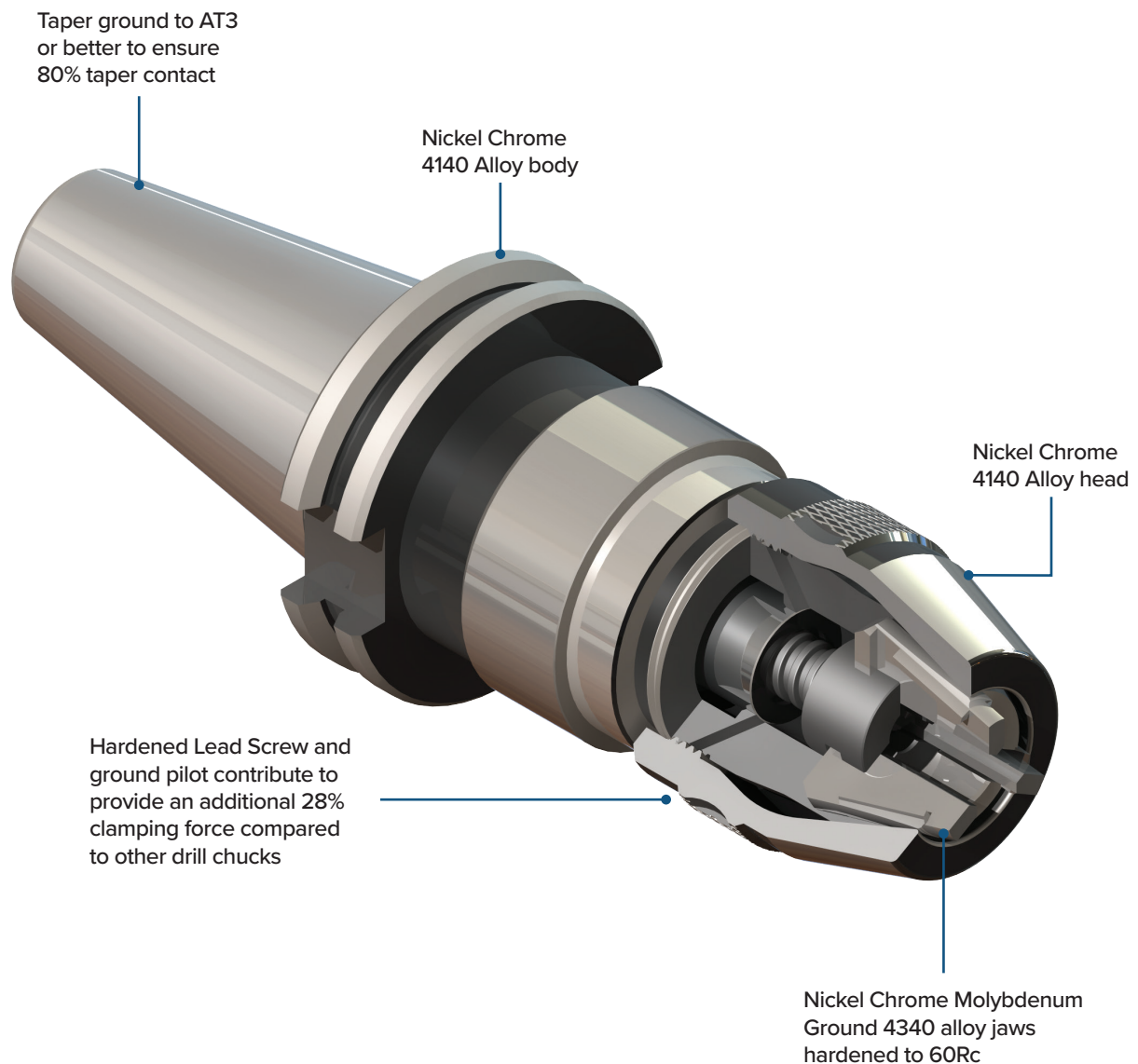

DRILL CHUCKS & MORSE TAPER HOLDERS

CAT & BT INTEGRAL KEYLESS DRILL CHUCKS

FEATURES

- Compact design and small head prevent drill slippage during operation



Speed

NPU8 is balanced to G6.3 @ 7,000 RPM
NPU13 is balanced to G6.3 @ 5,000 RPM

REAMING



DRILLING



CAT40/50 TAPER

Part Number	Capacity	L	L1	D
CAT40-NPU8-80U-IDU	5/16" (8.0mm)	3.31"	3.58"	1.52"
CAT40-NPU8-110U-IDU	5/16" (8.0mm)	4.53"	4.80"	1.52"
CAT40-NPU13-105U-IDU	1/2" (13.0mm)	4.35"	4.82"	1.93"
CAT40-NPU13-130U-IDU	1/2" (13.0mm)	5.41"	5.88"	1.93"
CAT50-NPU8-80U-IDU	5/16" (8.0mm)	3.37"	3.76"	1.52"
CAT50-NPU13-90U-IDU	1/2" (13.0mm)	3.71"	4.19"	1.93"

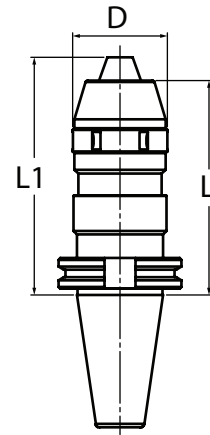

BT30/40/50 TAPER

Part Number	Capacity	L	L1	D
BT30-NPU8-70	5/16" (8.0mm)	2.99"	3.27"	1.52"
BT30-NPU13-95	1/2" (13.0mm)	4.03"	4.50"	1.93"
BT40-NPU8-70	5/16" (8.0mm)	2.99"	3.27"	1.52"
BT40-NPU8-110	5/16" (8.0mm)	4.53"	4.80"	1.52"
BT40-NPU13-80	1/2" (13.0mm)	3.40"	3.87"	1.93"
BT40-NPU13-130	1/2" (13.0mm)	5.41"	5.88"	1.93"
BT50-NPU13-90	1/2" (13.0mm)	3.83"	4.30"	1.93"
BT50-NPU13-130	1/2" (13.0mm)	5.41"	5.88"	1.93"
BT50-NPU13-190	1/2" (13.0mm)	7.77"	8.24"	1.93"

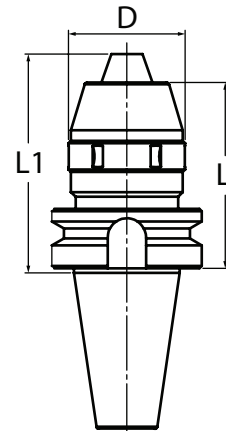

Drill Chuck Wrench
Page 193



Replacement Drill Chuck
Page 193

NMTB & HSK DRILL CHUCKS

FEATURES

- Compact design and small head prevent drill slippage during operation



Speed

NPU8 is balanced to G6.3 @ 7,000 RPM
NPU13 is balanced to G6.3 @ 5,000 RPM

REAMING



DRILLING



Please note that the maximum RPM listed in our catalog may vary depending on the toolholder shank, weight, balanceability and the G rating.

NMTB40/50

Part Number	Capacity	L	L1	D
NMTB40-NPU8-76	5/16" (8.0mm)	2.99"	3.27"	1.52"
NMTB40-NPU13-86	1/2" (13.0mm)	3.40"	3.87"	1.93"
NMTB50-NPU13-86	1/2" (13.0mm)	3.39"	3.86"	1.93"

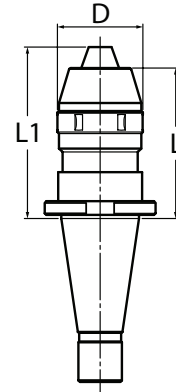

HSK63A/100A

Part Number	Capacity	L	L1	D
HSK63A-NPU8-120	5/16" (8.0mm)	4.73"	5.00"	1.52"
HSK63A-NPU13C-135-IDU**	1/2" (13.0mm)	5.36"	5.83"	1.93"
HSK100A-NPU13C-145-IDU**	1/2" (13.0mm)	5.71"	6.18"	1.93"

Note:

- Coolant Tubes and Coolant Tube Wrenches are sold separately. See page 153 for more details.
- **Coolant-thru capable

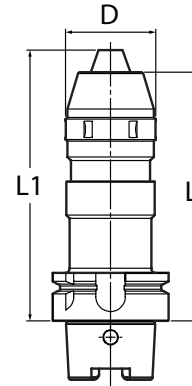



DRILL CHUCK ACCESSORIES

REPLACEMENT WRENCH FOR DRILL CHUCK

Part Number	Description
NPU8-SPAN	Fits 5/16" (8.0mm) Chucks
NPU13-SPAN	Fits 1/2" (13.0mm) Chucks



REPLACEMENT DRILL CHUCK

Part Number	Description
9NPU-8	Replacement 1/4" Chuck
9NPU-13	Replacement 1/2" Chuck



COOLANT TUBE WRENCH FOR HSK HOLDERS

Part Number	Description
HSK63-WRENCH	Wrench for HSK63 Coolant Tube
HSK100-WRENCH	Wrench for HSK100 Coolant Tube



COOLANT TUBE FOR HSK HOLDERS

Part Number	Description
HSK63-TUBE	Coolant Tube for HSK63 Holders
HSK100-TUBE	Coolant Tube for HSK100 Holders





T.I.R.
0.0002" at JT pilot

REAMING DRILLING

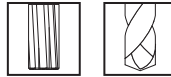

CAT & BT JACOBS® TAPER HOLDERS

CAT40/50

Part Number	JT Size	L	D
C4003-0002-1.61	JT#2	1.61"	0.56"
C4003-0003-1.58	JT#3	1.58"	0.81"
C4003-0004-1.49	JT#4	1.49"	1.12"
C4003-0006-1.61	JT#6	1.61"	0.68"
C4003-0033-1.61	JT#33	1.61"	0.63"
C5003-0002-1.61	JT#2	1.61"	0.56"
C5003-0003-1.75	JT#3	1.75"	0.81"
C5003-0004-1.49	JT#4	1.49"	1.12"
C5003-0006-1.61	JT#6	1.61"	0.68"
C5003-0033-1.61	JT#33	1.61"	0.63"

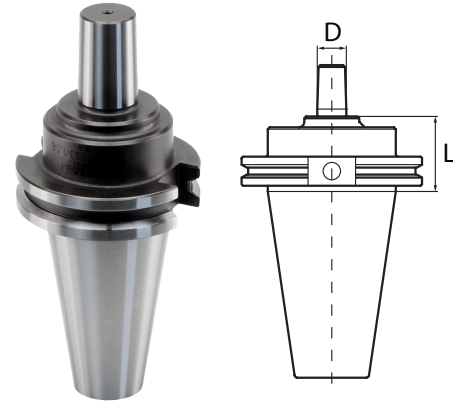

BT30

Part Number	JT Size	L	D
B3003-0001-1.06	JT#1	1.06"	0.38"
B3003-0002-1.02	JT#2	1.02"	0.56"
B3003-0003-0.98	JT#3	0.98"	0.81"
B3003-0006-1.02	JT#6	1.02"	0.68"
B3003-0033-1.02	JT#33	1.02"	0.63"

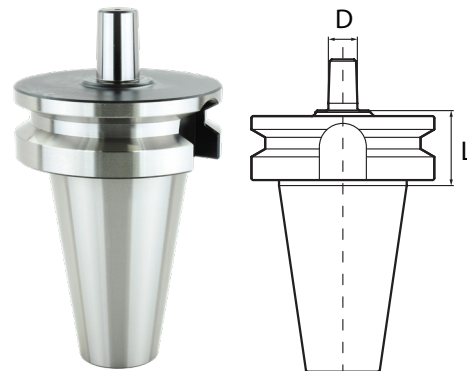

BT40

Part Number	JT Size	L	D
B4003-0002-1.61	JT#2	1.61"	0.56"
B4003-0003-1.75	JT#3	1.75"	0.81"
B4003-0006-1.61	JT#6	1.61"	0.68"
B4003-0033-1.61	JT#33	1.61"	0.63"

BT50

Part Number	JT Size	L	D
B5003-0002-1.61	JT#2	1.61"	0.56"
B5003-0003-1.57	JT#3	1.57"	0.81"
B5003-0004-1.49	JT#4	1.49"	1.12"
B5003-0006-1.61	JT#6	1.61"	0.68"
B5003-0033-1.61	JT#33	1.61"	0.68"



DRILL CHUCKS & MORSE TAPER HOLDERS

NMTB & R8 JACOBS® TAPER HOLDERS

NMTB30

Part Number	JT Size	L	D
N3003-0002-0.59	JT#3	0.59"	0.81"
N3003-0003-0.55	JT#3	0.55"	0.81"
N3003-0006-0.59	JT#6	0.59"	0.68"
N3003-0033-0.59	JT#33	0.59"	0.63"

NMTB40

Part Number	JT Size	L	D
N4003-0001-0.69	JT#1	0.69"	0.38"
N4003-0002-0.65	JT#2	0.65"	0.56"
N4003-0003-0.61	JT#3	0.61"	0.81"
N4003-0006-0.65	JT#6	0.65"	0.68"
N4003-0033-0.65	JT#33	0.65"	0.63"

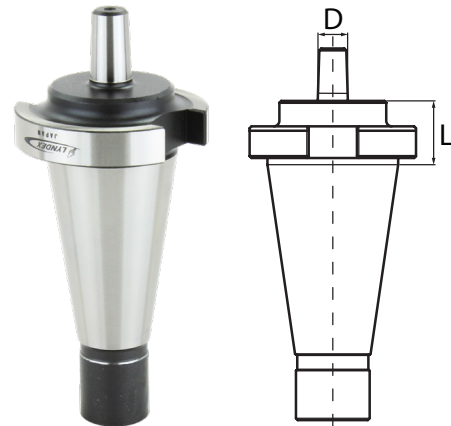

NMTB50

Part Number	JT Size	L	D
N5003-0002-1.34	JT#2	1.34"	0.56"
N5003-0003-1.30	JT#3	1.30"	0.56"
N5003-0004-1.22	JT#4	1.22"	1.12"
N5003-0006-1.34	JT#6	1.34"	0.68"
N5003-0033-1.34	JT#33	1.34"	0.63"

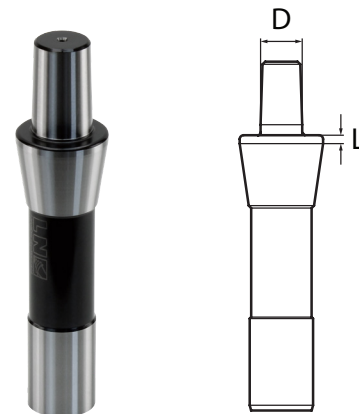

R8

Part Number	JT Size	L	D
870-001-0.13	JT#1	0.13"	0.38"
870-002-0.13	JT#2	0.13"	0.56"
870-003-0.13	JT#3	0.13"	0.81"
870-006-0.13	JT#6	0.13"	0.68"
870-033-0.13	JT#33	0.13"	0.63"



JACOBS® DRILL CHUCK ACCESSORIES

JACOBS® BRAND DRILL CHUCK

Part Number	Style	Jacobs® Taper Size	Description
8-1/2N	0 - 1/4"	JT#2	Heavy Duty Ball Bearing Chuck
100-J2	0 - 3/8"	JT#2	High Precision Keyless Chuck
100-J33	0 - 3/8"	JT#33	High Precision Keyless Chuck
11N	0 - 3/8"	JT#2	Heavy Duty Ball Bearing Chuck
130-JT33	1/32 - 1/2"	JT#33	High Precision High Torque Keyless Chuck
14N	0 - 1/2"	JT#3	Heavy Duty Ball Bearing Chuck
160-J6	1/8 - 5/8"	JT#6	High Precision Keyless Chuck
16N	1/8 - 5/8"	JT#3	Heavy Duty Ball Bearing Chuck
18N	1/8 - 3/4"	JT#4	Heavy Duty Ball Bearing Chuck
34-02	0 - 1/2"	JT#2	Heavy Duty Plain Bearing Chuck
34-06	0 - 1/2"	JT#6	Heavy Duty Plain Bearing Chuck
34-33	0 - 1/2"	JT#33	Heavy Duty Plain Bearing Chuck



REPLACEMENT KEY

Part Number	Description
K-3	Key for Plain Bearing Chuck



DRILL CHUCKS & MORSE TAPER HOLDERS

CAT & BT MORSE TAPER HOLDERS



T.I.R.
0.0002" at ID bore

REAMING DRILLING



CAT40/50

Part Number	Size	L	D	D1
C4004-0001-1.75	MT#1	1.75"	0.48"	0.99"
C4004-0002-2.36	MT#2	2.36"	0.70"	1.26"
C4004-0003-3.00	MT#3	3.00"	0.94"	1.57"
C4004-0004-3.54	MT#4	3.54"	1.23"	1.97"
C5004-0002-1.75	MT#2	1.75"	0.70"	1.26"
C5004-0003-1.75	MT#3	1.75"	0.94"	1.57"
C5004-0004-3.00	MT#4	3.00"	1.23"	1.97"
C5004-0005-4.13	MT#5	4.13"	1.75"	2.75"

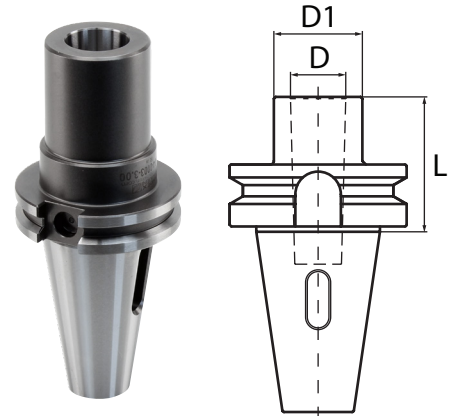

BT30/40/50

Part Number	Size	L	D	D1
B3004-0001-1.75	MT#1	1.75"	0.48"	0.99"
B3004-0002-2.36	MT#2	2.36"	0.70"	1.26"
B4004-0001-1.75	MT#1	1.75"	0.48"	0.99"
B4004-0002-2.36	MT#2	2.36"	0.70"	1.26"
B4004-0003-3.00	MT#3	3.00"	0.94"	1.57"
B4004-0004-3.54	MT#4	3.54"	1.97"	1.97"
B5004-0002-1.75	MT#2	1.75"	0.70"	1.26"
B5004-0003-1.75	MT#3	1.75"	0.94"	1.57"
B5004-0004-3.00	MT#4	3.00"	1.57"	1.97"
B5004-0005-4.13	MT#5	4.13"	1.75"	2.75"

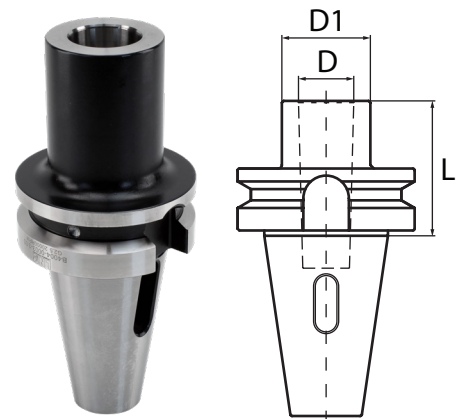

R8 MORSE TAPER HOLDERS



T.I.R.
0.0002" at ID bore

REAMING



DRILLING



R8

Part Number	Size	L	D	D1
840-002-0.44	MT#2	0.44"	0.70"	1.26"
840-003-2.56	MT#3	2.13"	0.94"	1.57"

