

STUB MILL HOLDERS & BLANK BARS



STUB & BLANK

**STUB MILL HOLDERS
& BLANK BARS**



STUB MILL HOLDER FEATURES

Our Stub Mill Holders feature hardened and ground tapers, location shafts and arbor spacers to ensure clamping of cutting tools and rigid machining capability.

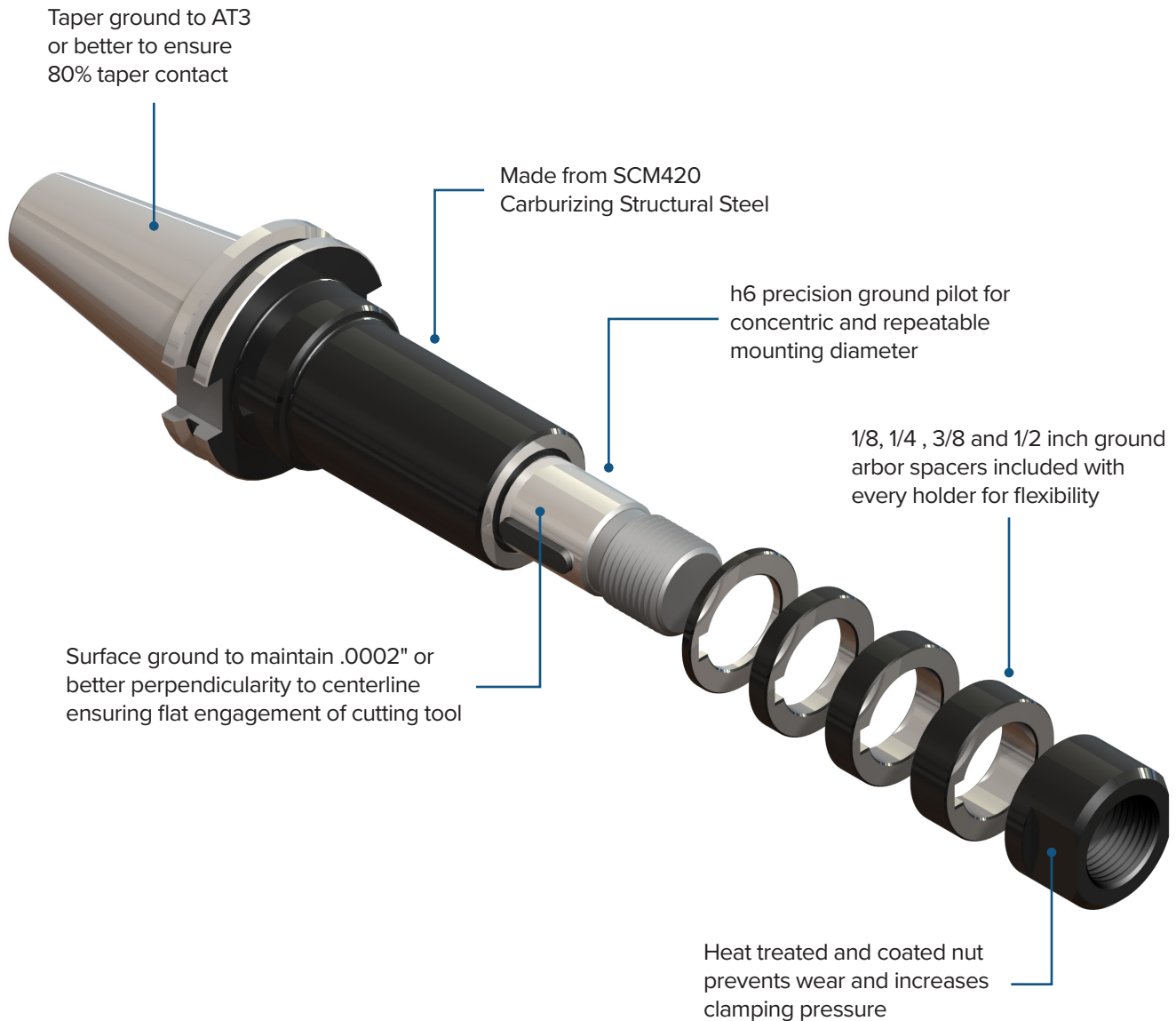

STUB & BLANK

STUB MILL HOLDERS



CAT & BT STUB MILL HOLDERS

FEATURES

- Taper ground to AT3 or better to ensure 80% taper contact
- 1/8", 1/4", 3/8" and 1/2" ground arbor spacers included with every holder
- h6 precision ground pilot for concentric and repeatable mounting diameter



T.I.R.
< 0.0002" run out at pilot



Set-Up
Quick and easy

CAT40/50

Part Number	Taper	d	L	D	L1	Key Size
C4002-1000-6.17	CT40	1"	6.17"	1.50"	4.00"	1/4"
C4002-1250-6.29	CT40	1-1/4"	6.29"	1.77"	4.00"	5/16"
C4002-1500-6.60	CT40	1-1/2"	6.60"	2.17"	4.00"	3/8"
C5002-1000-6.17	CT50	1"	6.17"	1.50"	4.00"	1/4"
C5002-1250-6.28	CT50	1-1/4"	6.28"	1.77"	4.00"	5/16"
C5002-1500-6.60	CT50	1-1/2"	6.60"	2.17"	4.00"	3/8"

Notes:

- 1 pcs. each: 1/8", 1/4", 3/8" and 1/2" arbor spacers and securing nut included as standard with all listed toolholders.

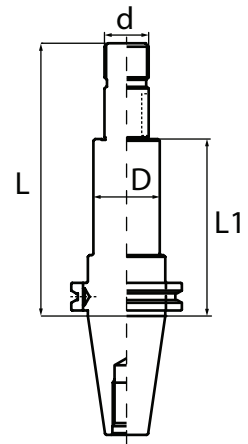

BT30/40

Part Number	Taper	d	L	D	L1	Key Size
B3002-0750-4.97	BT30	3/4"	4.97"	1.26"	3.00"	1/4"
B3002-1000-5.17	BT30	1"	5.17"	1.50"	3.00"	1/4"
B4002-1000-5.18	BT40	1"	5.18"	1.50"	3.00"	1/4"
B4002-1250-5.32	BT40	1-1/4"	5.32"	1.77"	3.00"	1/4"
B4002-1500-5.60	BT40	1-1/2"	5.60"	2.17"	3.00"	1/4"

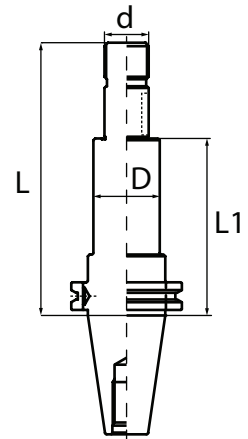

NCAT40/50

Part Number	Taper	d	L	D	L1	Key Size
NC4002-1000-6.17	NCAT40	1"	6.17"	1.50"	4.00"	1/4"
NC4002-1250-6.29	NCAT40	1-1/4"	6.29"	1.77"	4.00"	5/16"
NC5002-1000-6.17	NCAT50	1"	6.17"	1.50"	4.00"	1/4"

CAT & BT STUB MILL HOLDER ACCESSORIES

REPLACEMENT KEY FOR STUB MILL HOLDERS

Part Number	Description
3/4-STUBKEY	3/4"
1-STUBKEY	1"
1-1/4-STUBKEY	1-1/4"
1-1/2-STUBKEY	1-1/2"

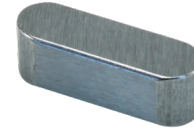

REPLACEMENT NUT FOR STUB MILL HOLDERS

Part Number	Description	Length of Nut
3/4-STUBNUT	3/4"	18mm (0.70")
1-STUBNUT	1"	22.5mm (0.88")
1-1/4-STUBNUT	1-1/4"	22.5mm (0.88")
1-1/2-STUBNUT	1-1/2"	33.5mm (1.31")

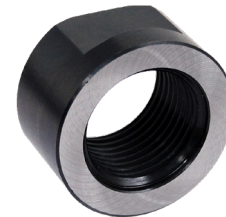

REPLACEMENT SPACER FOR STUB MILL HOLDERS

Part Number	Description
SP3/4-1/8	1/8" Thick Spacer for 3/4" OD Holder
SP3/4-1/4	1/4" Thick Spacer for 3/4" OD Holder
SP3/4-3/8	3/8" Thick Spacer for 3/4" OD Holder
SP3/4-1/2	1/2" Thick Spacer for 3/4" OD Holder
SP1-1/8	1/8" Thick Spacer for 1" OD Holder
SP1-1/4	1/4" Thick Spacer for 1" OD Holder
SP1-3/8	3/8" Thick Spacer for 1" OD Holder
SP1-1/2	1/2" Thick Spacer for 1" OD Holder
SP1-1/4-1/8	1/8" Thick Spacer for 1-1/4" OD Holder
SP1-1/4-1/4	1/4" Thick Spacer for 1-1/4" OD Holder
SP1-1/4-3/8	3/8" Thick Spacer for 1-1/4" OD Holder
SP1-1/4-1/2	1/2" Thick Spacer for 1-1/4" OD Holder
SP1-1/2-1/8	1/8" Thick Spacer for 1-1/2" OD Holder
SP1-1/2-1/4	1/4" Thick Spacer for 1-1/2" OD Holder
SP1-1/2-3/8	3/8" Thick Spacer for 1-1/2" OD Holder
SP1-1/2-1/2	1/2" Thick Spacer for 1-1/2" OD Holder



BLANK BARS



CAT & BT BLANK BARS

FEATURES

- Taper ground to AT3 or better to ensure 80% taper contact
- Suitable for all applications – even deep boring
- Ground and hardened surfaces except projection of the toolholder



Coolant-Thru
Opt. modification

CAT40/50

Part Number	Taper	L	D
C4008-0013	CAT40	13.00"	2.50"
C5008-0013	CAT50	13.00"	3.88"



BT30/40/50

Part Number	Taper	L	D
B3008-0008	BT30	8.00"	2.25"
B4008-0013	BT40	13.00"	2.50"
B5008-0013	BT50	13.00"	3.88"

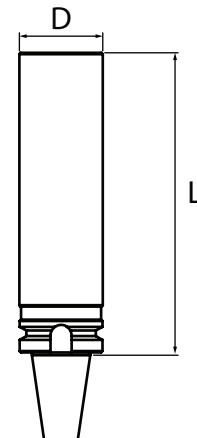

STUB & BLANK

TAPER PLUS CAT BLANK BARS

TAPER PLUS - NCAT40/50

Part Number	Taper	L	D
NC4008-0013	NCAT40	13.00"	2.50"
NC5008-0013	NCAT50	13.00"	3.88"

NMTB & HSK BLANK BARS

NMTB40/50

Part Number	Taper	L	D
N4008-0013	NMTB40	13.00"	2.50"
N5008-0013	NMTB50	13.00"	3.88"

NMTB shanks are suitable for use with Erickson Quick Change spindles.

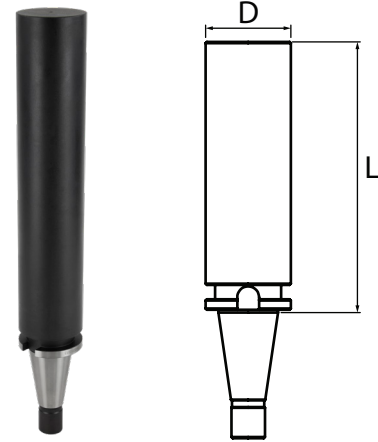

HSK63A/100A

Part Number	Taper	L	D
HSK63A-BLANK-13.00	HSK63A	13.00"	2.50"
HSK100A-BLANK-13.00	HSK100A	13.00"	3.76"

Note:

- Coolant tube and coolant tube wrench are not included.
- Other HSK sizes are available as specials. Please contact us for more information.

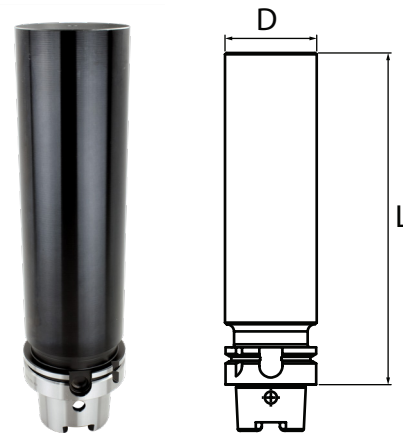

STUB & BLANK

COOLANT TUBE WRENCH FOR HSK HOLDERS

Part Number	Description
HSK63-WRENCH	Wrench for HSK63 Coolant Tube
HSK100-WRENCH	Wrench for HSK100 Coolant Tube

Note:

- Coolant tube wrenches are needed to remove or install coolant tubes in HSK toolholders.



COOLANT TUBE FOR HSK HOLDERS

Part Number	Description
HSK63-TUBE	Coolant Tube for HSK63 Holders
HSK100-TUBE	Coolant Tube for HSK100 Holders

