

STRAIGHT LIVE TOOL
 OUTPUT: ER25 DUAL MAIN & SUB
 MAX RPM: 6,000
 COOLANT: EXTERNAL

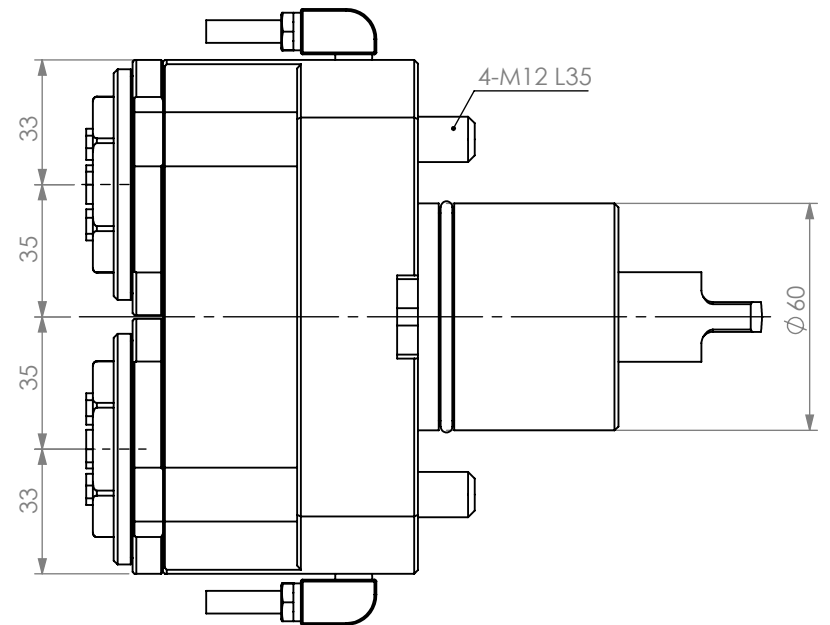

ITEM	PART NO.	DESC.	QTY.
1	NUT-ER25I	Inlying Nut ER25	2
2	WRENCH-ER25I	Nut Wrench	1
3	SP-41	Spindle Wrench	1
4			
5			

PROPRIETARY AND CONFIDENTIAL

THE INFORMATION CONTAINED IN THIS DRAWING IS THE SOLE PROPERTY OF LYNDEX NIKKEN. ANY REPRODUCTION IN PART OR AS A WHOLE WITHOUT THE WRITTEN PERMISSION OF LYNDEX NIKKEN IS PROHIBITED. DRAWING SUBJECT TO CHANGE WITHOUT NOTICE.

NAME	DATE
DRAWN BT	2/8/2021

NOTES:
 Ref# MSA01-6K000

STRAIGHT LIVE TOOL ER25 DUAL M/SUB OUTPUT



SIZE	DWG. NO.	REV.
A	MNL12-ER25X-MSD	

SCALE 1:2 SHEET 1 OF 1