



ER25 OD Drill/Milling Unit 2 Output Y-Axis (Main)

Part #: MNL12-ER25Y-MD



Clockwise Input

Clockwise Output

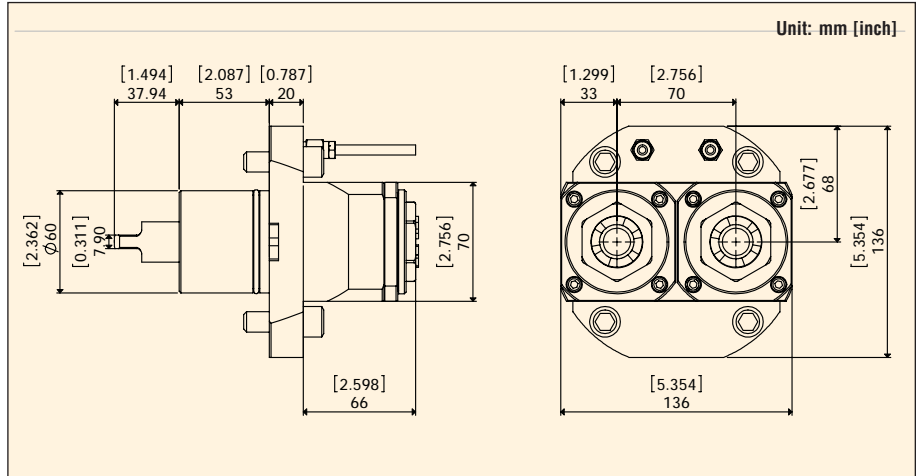

External or Internal Coolant	Radial/Axial	Max. RPM	Gear Ratio	Max. Torque Output	Collet Size	Replacement Nut	Coolant Nozzle	Spanner Wrench for Nut	
								for Spindle	for Nut
External	Radial	6000	1:1	11ft-lbs (15N-m)	ER25 (1/16" to 5/8")	Hi-Q/ERAX25	PIPE	SP-41	E 25 AX

Please refer to pages 57 - 60 for ER Series Collets and ER Tap Collets details.

ER20 Adjustable Angle Drill/Milling Unit

Part #: MNL12-ER20-AD

Mori Seiki Part #: T32474

Clockwise Input

Clockwise Output

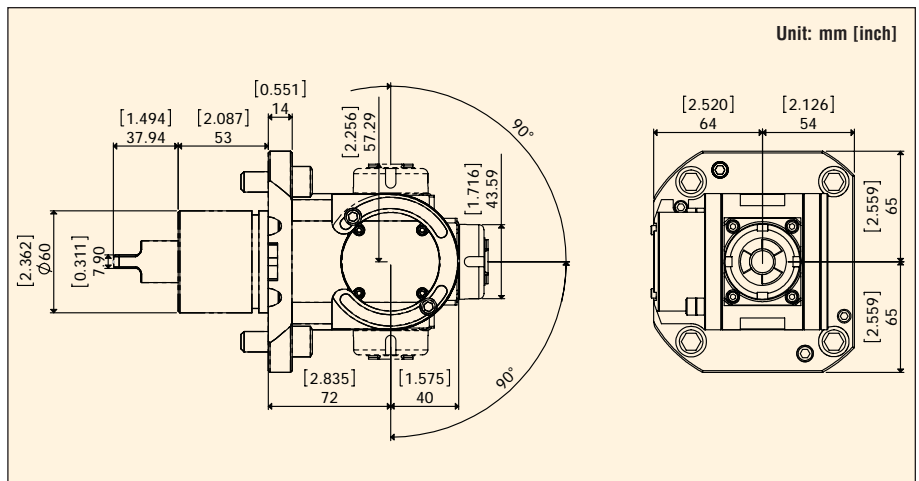

External or Internal Coolant	Radial/Axial	Max. RPM	Gear Ratio	Max. Torque Output	Center Height (mm)	Collet Size	Replacement Nut	Coolant Nozzle	Spanner Wrench for Nut	
									for Spindle	for Nut
External	X-Z	4000	1:1	29.5ft-lbs (40N-m)	72	ER20 (1/16" to 1/2")	Hi-Q/ERAX20	PAP CU6x4x130	FK-7	E20 AX

Please refer to pages 57 - 60 for ER Series Collets and ER Tap Collets details.